



# Defender Filter Manual



## Oversigt

<b>DEFENDER MEDIE PRINCIP TEGNING .....</b>	<b>1</b>
GENERAL .....	2
POSITIONERING OG OPSTILLING AF TANKE .....	2
ANKER INSTALLATION AF TANK BEN .....	3
 <b>INSTALLATION.....</b>	 <b>4</b>
MONTERINGS KOMPONENTER .....	4
MANOMETER PANEL .....	4
FILTER / REGULATOR (F/R) .....	4
VAKUUM BLÆSER .....	5
RMF KONTROL BOKS .....	5
VAKUUM SLANGE BESLAG .....	6
INSTALLATION AF VAKUUM BLÆSER .....	7
RMF PROGRAMMER WIRING – 120V .....	8
RMF PROGRAMMER WIRING – 240V .....	12
RMF KONTROL BOKS & FILTER / REGULATOR .....	17
KONTROL BOKS.....	18
PNEUMATISKE MAGNETVENTILER.....	18
PNEUMATISKE MAGNETVENTIL FORBINDELSER.....	19
PNEUMATISK SETUP FOR AKTUATOR.....	19
LUFTJUSTERINGER AF VENTILER.....	20
CYLINDER ENDER .....	20
PNEUMATISK RØR INSTALLATION .....	21
VAKUUM SYSTEM.....	22
VAKUUM SLANGE OG FILTER JORDLEDNING.....	23
DEFENDER AKTUATOR TILPASNINGER.....	24
DET ANBEFALES AT AKTUATOREN MONTERES "VINKELRET" TIL RØRSYSTEMET .....	24
AKTUATOREN MONTERES PARALLEL MED RØRENE (VALG FRIT) .....	24
FLOW (SPEED) REGULERINGSVENTILER.....	24
PNEUMATISK AKTUATOR JUSTERINGER – VINKELRET MONTERING .....	25
PVC FLANGE INSTALLATIONS DATA .....	26
INSTALLATION AF BUTTERFLY VENTILER.....	27
BUTTERFLY VENTILER.....	28
PRESSURE GAUGES .....	29
SUPPORT SPACING FOR PVC.....	29
 <b>OPERATION.....</b>	 <b>31</b>
PRE START- UP CHECK .....	31
TØR AFPRØVNING .....	31
QUICK START INSTRUKTION.....	32
INDLÆSNING AF MEDIE I SYSTEMET - VAKUUM OVERFØRELSE.....	32
CYCLE START .....	33
GENOPFYLDNING AF MEDIE .....	33
GÅ RETUR TIL OPERATIONS MODE, HVIS CIRKULATIONSPUMPEN STOPPER .....	33
ILLUSTRATED OPERATING MANUAL.....	34

---

<b>VEDLIGEHOELDELSE .....</b>	<b>48</b>
GENERAL .....	48
INDENDØRS BASSIN .....	48
UDENDØRS BASSIN .....	48
MELLEM KEMISK RENSNING .....	48
HEAD GASKET .....	48
FEM ÅRS VEDLIGEHOELDELSE .....	48
TI ÅRS VEDLIGEHOELDELSE .....	49
RENGØRING AF FLEKSIBLE RØR .....	49
BUMP ASSEMBLY .....	50
UR .....	51
ACCESSORY COMPONENTS BLOWER MANUAL .....	54
FILTER/REGULATOR .....	63
WATER SEPARATOR .....	68
<b>DEFENDER FEJLFINDINGS TIPS .....</b>	<b>73</b>
VACUUM TRANSFER MOTOR .....	73
RMF PROGRAMMER .....	73
PNEUMATIC ACTUATORS .....	74
FILTER TANK .....	74
BUMP MECHANISM .....	74
<b>INSTRUKTIONER TIL NÅR DEFENDER FILTRET LUKKER NED .....</b>	<b>75</b>

---

# DEFENDER PRINCIP SKEMA

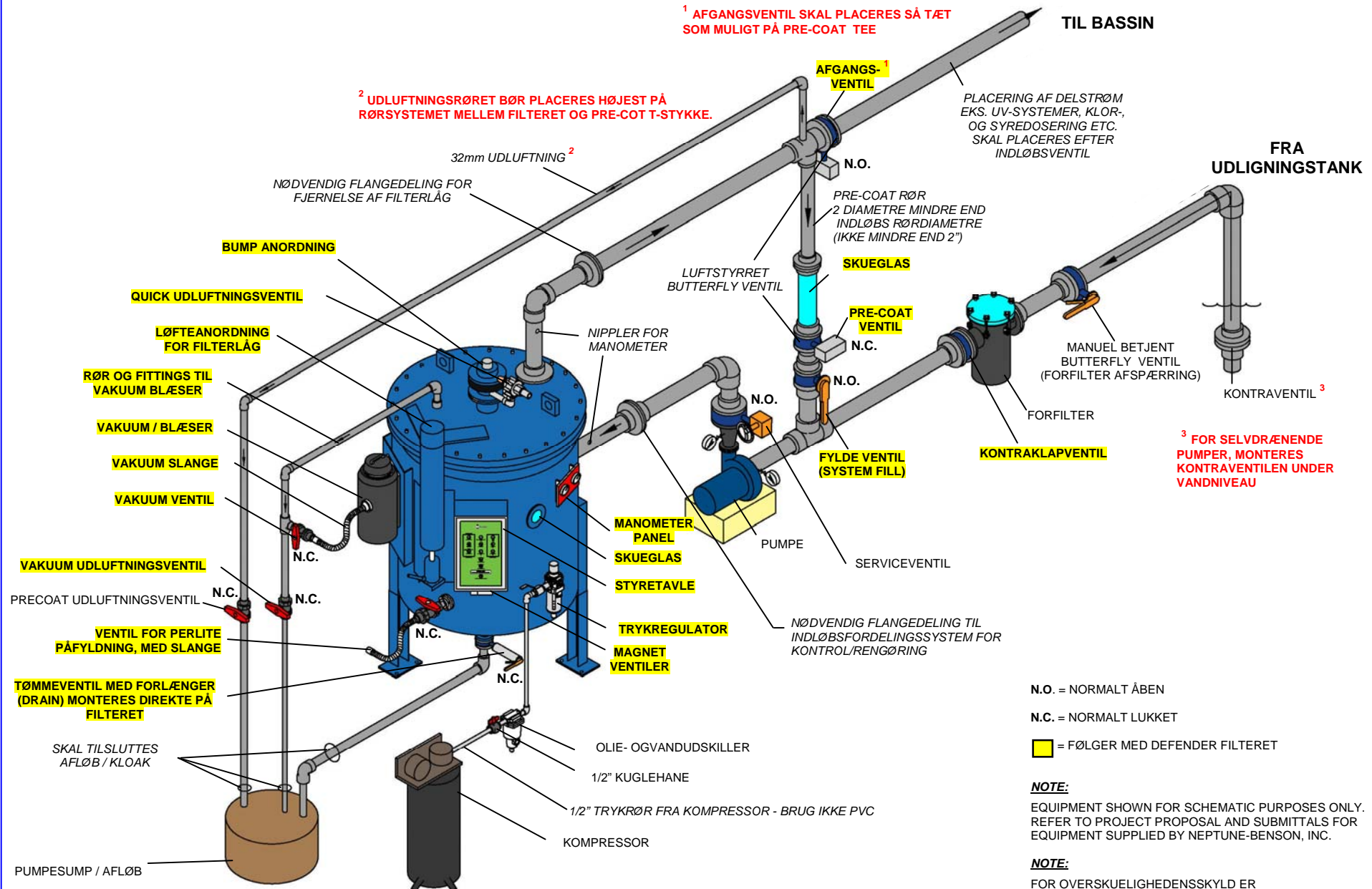

**FORSIGTIG**

Opbevar eller installer ikke filter rør steder hvor temperaturer overstiger grænserne for materialerne. For udendørs anlæg, skal du huske, at temperaturerne i filteret kan variere meget fra aktuelle ude temperaturer. Filter tanke må ikke udsættes for direkte sollys eller varme omgivende temperaturer under opbevaring, eller når systemet er lukket ned i længere perioder. Kontakt Neptun Benson for eventuelle spørgsmål vedrørende lagring eller installation procedurer for tanke og rør.

**GENERELT**

Kontroller egnethed og mængde af alle poster. Henviser til Bill of Materials om filter tegning(er) og Shipping liste.

**Positionering og opstilling af tanke**

1. Filter indeholder indre dele, som er vertikalt indsat. Filteret skal transporteres og håndteres i en opretstående stilling på alle tidspunkter.

**BEMÆRK!**

Hvis filteret skal anbringes vandret af adgangs grunde, skal bump mekanismen trykkes mindst 75 P.S.I. før tanken vippes. (Se figur 1)



Figure 1

**Manglende tryk på bump mekanisme, kan beskadige filteret og gøre det ubrugeligt.**

**Sæt filtret tilbage i den lodrette position ASAP!**

Efterlad eller opbevares ikke i vandret stilling. Når tanken er fastsat i den endelige lodret position, bump enhed 5-6 gange for at kontrollere driften.

2. Filteret må kun løftes i øjebolt placeret på toppen af filteret.
3. Filteret skal være installeret vandret. Entreprenøren skal vatte filtret ud. I hvert ben er der lavet huller så filtret kan forankres til betongulvet.
4. Filtret skal jordforbindes. Korrekt jordforbindelse er afgørende for at undgå korrosion. Se side 24 for jordforbindelses steder.

**FORSIGTIG**

Filtret er udstyret med monterings anker for at sikre det til gulvet. Ankerne skal installeres ifølge fabrikantens instruktioner før man forsøger at løfte filtrets top.

**Installeres filtret ikke korrekt til gulvet, kan det medføre fysisk og materiel skade.**

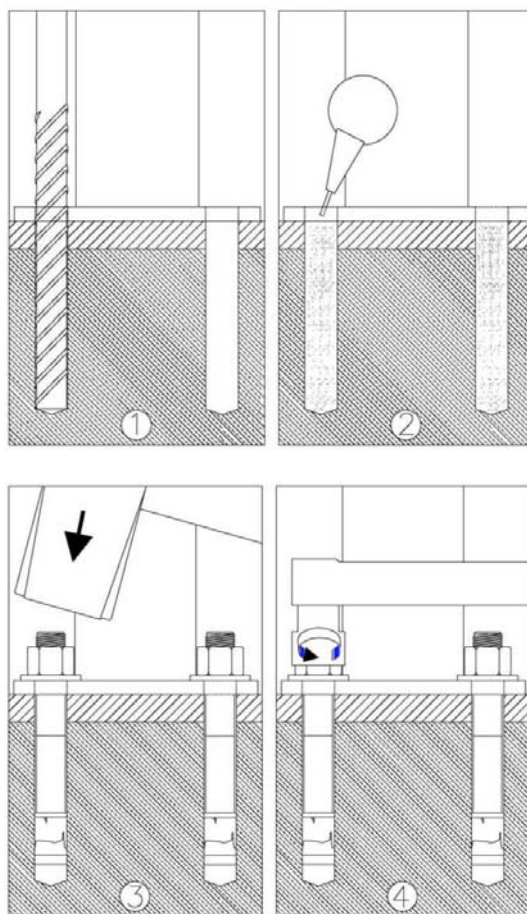

1. Med filtret i rette placering, monteres 16 x 150 slaganker i fodpladerne.
2. Efter boring af huller, fjernes alt støv fra hullerne.
3. Placer spændeskiver og møtrikker på slagankeret. Monter slaganker i fodpladen.
4. Spænd boltene til 120 FT.LBS.



## INSTALLATION

### MONTERINGS KOMPONENTER

Disse komponenter er ikke monteret på Defender filteret, men leveres løst ved siden af.

### MANOMETER PANEL

Bolt Manometer panel til monteringspladen som vist. 1/4" x 1" lange skruer, spændeskiver & møtrikker er inkluderet.

Tilslut indløbslange til manometer her.

Tilslut slange til manometer her.

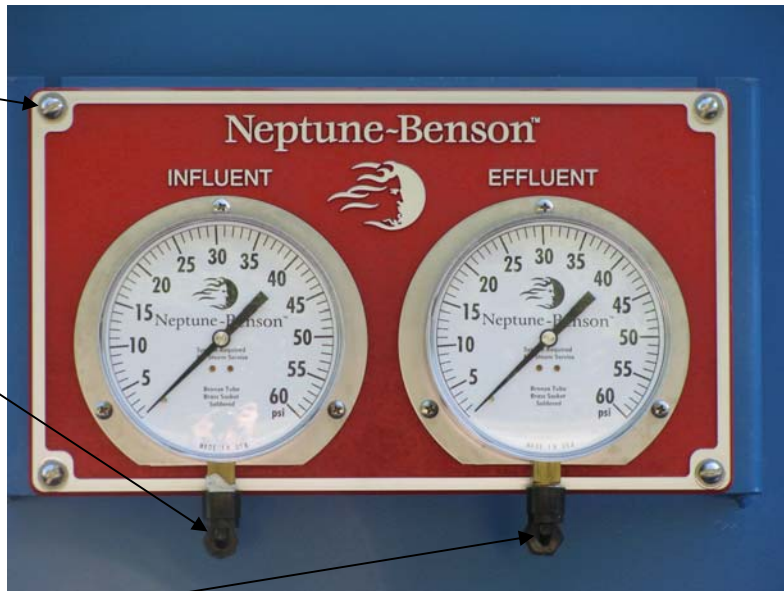

### FILTER / REGULATOR (F/R)

Tilslut fra compressoren  
Se side 16

Tilslut til magnetventiler,  
under kontrol  
boksen.

Bolt til monteringspladen, placeret under filter instruktion data plade. 1/4" x 1" lang skrue, spændeskive & møtrikker er inkluderet.

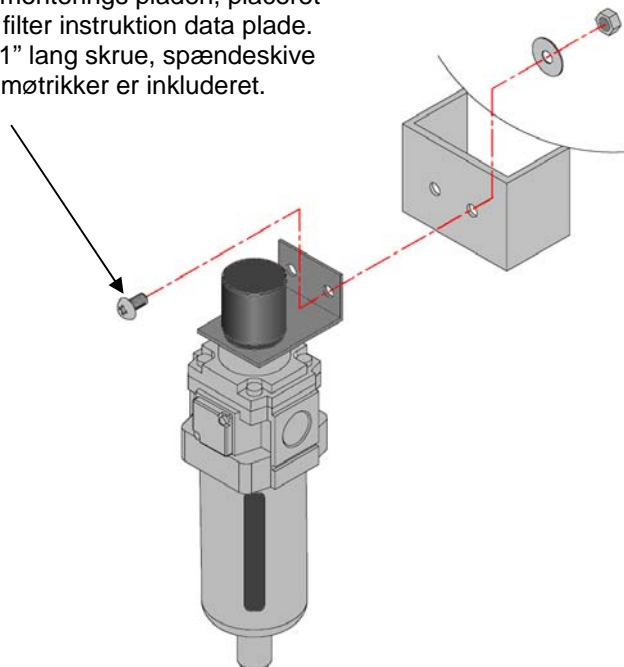
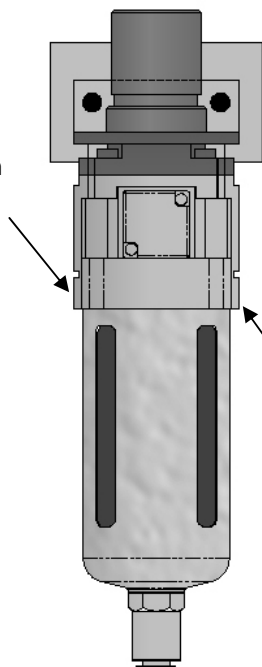

**1.5 HP:**

1/2-13 Hex Head Bolt x 2" lg.  
med spændeskiver og møtrikker.

**.5 HP:**

3/8-16 Hex Head Bolt x 1 1/2" lg.  
med spændeskiver og møtrikker.

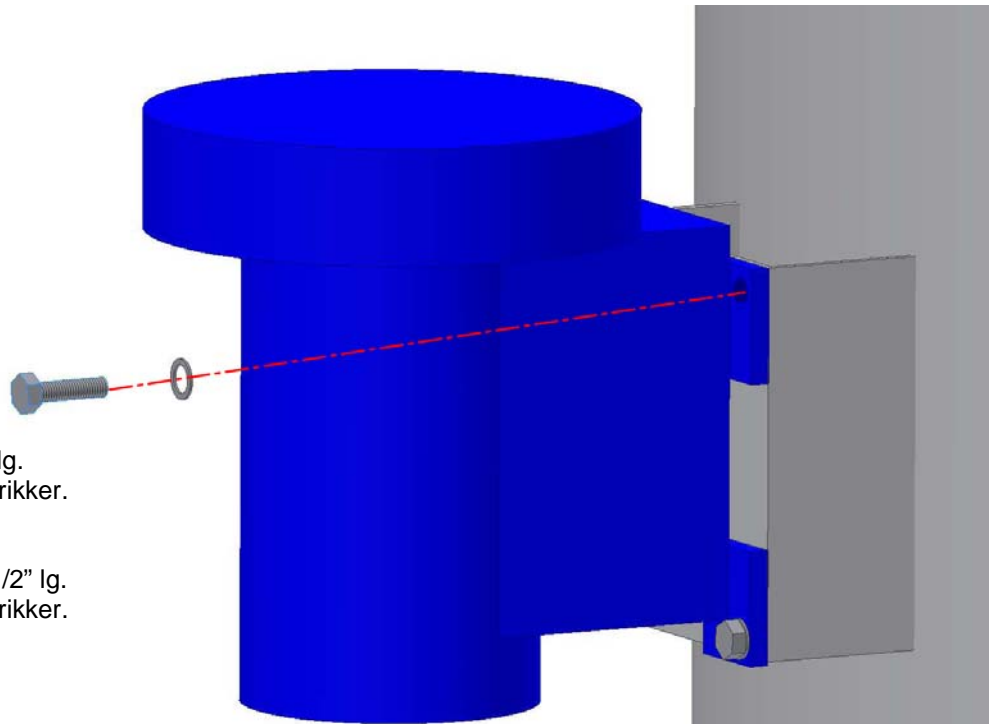

**BEMÆRK:** Defender Filter og tilbehør, skal beskyttes mod vind og vejr.

**RMF KONTROL BOKS**

1. Sæt bolt og spændeskive løst I de øverste huller i boksen.
2. Lad dem glide ind I rillerne på holderen
3. Installer bolte I bunden af holderen.

#10-32 Hex Head Bolt x 3/4" lange  
med spændeskiver, inkluderet.

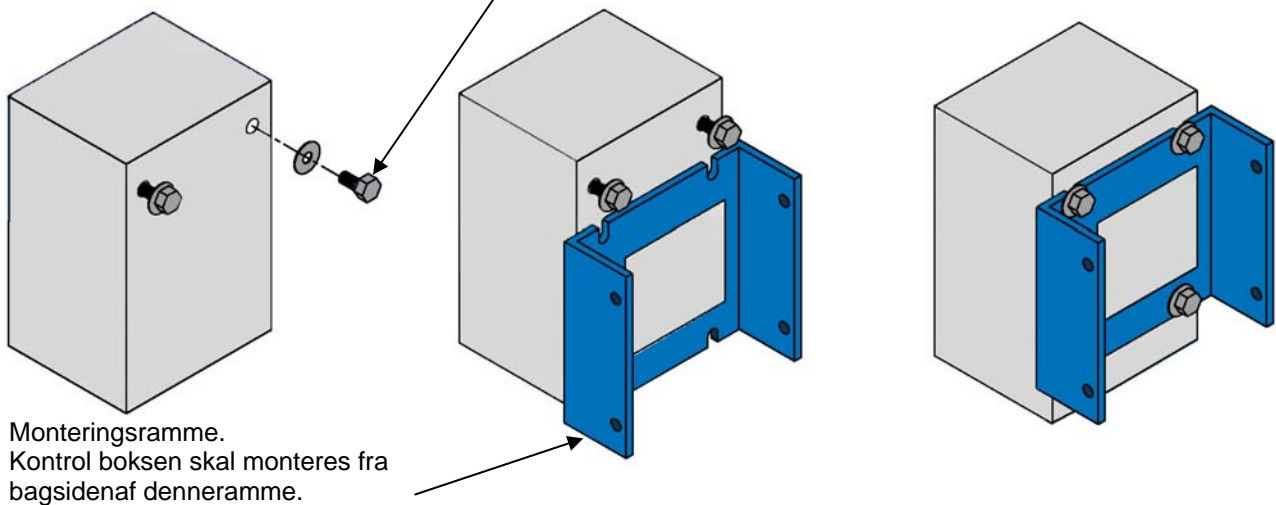



## VAKUUM SLANGE BESLAG

Bolt Til monteringsstedet med 1/4" x 1" lange skruer, spændeskiver & møtrikker er inkluderet.

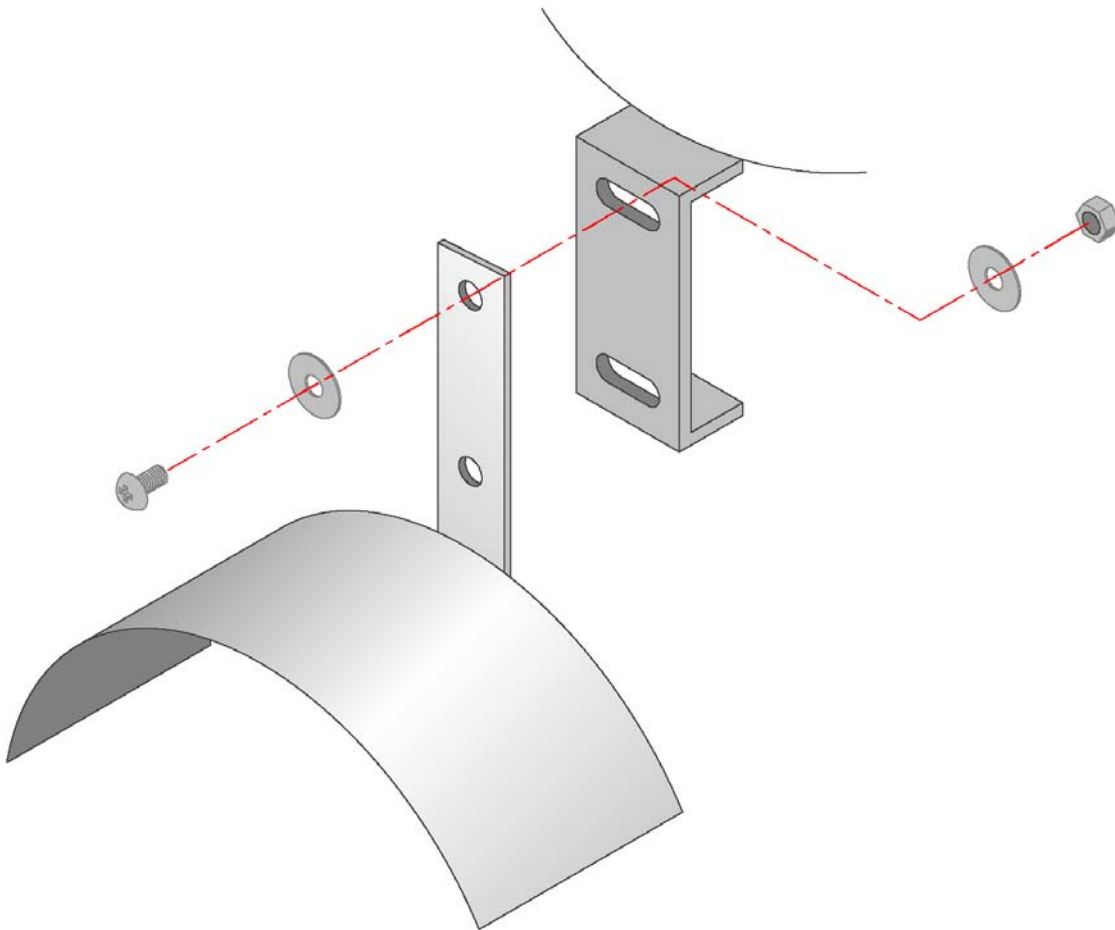

**INSTALLATION AF VAKUUM BLÆSER**

230V til vacuum blæser.

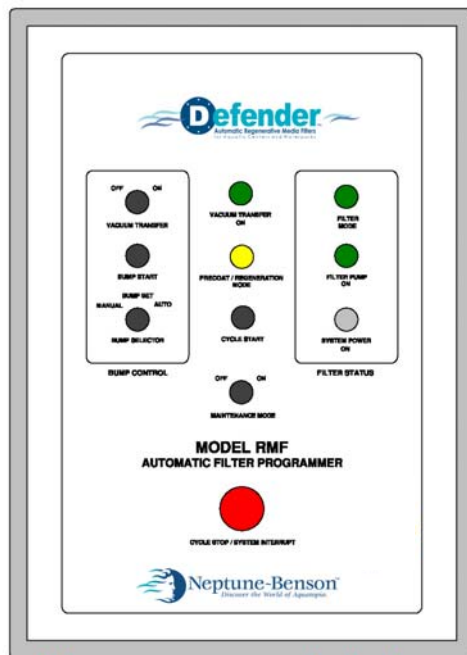
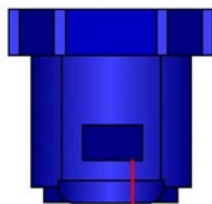

**Bemærk!**  
Alle elektriske forbindelser skal forestages igennem bunden af kabinettet.

PG tilslutning til elektriske komponenter

230V to power RMF.  
30 amps.

**Felt ledningsforbindelser**

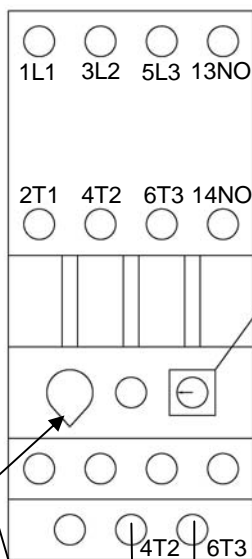
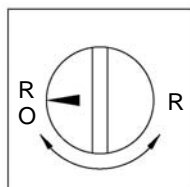

Hvid fra vacuum suger til forbindelse #6T3  
Sort fra vacuum suger til forbindelse #4T2

Sæt til 20 amps for 1½ hp blæser  
Sæt til 7 amps for ½ hp blæser

**Gast blæser**

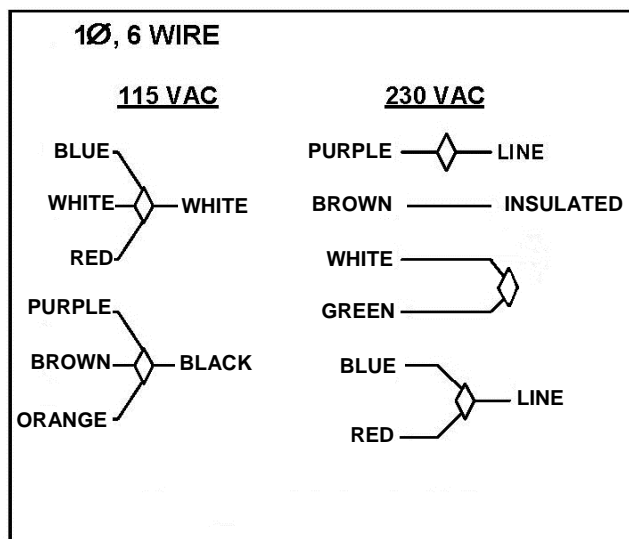

**RMF PROGRAMMER WIRING – 120V**

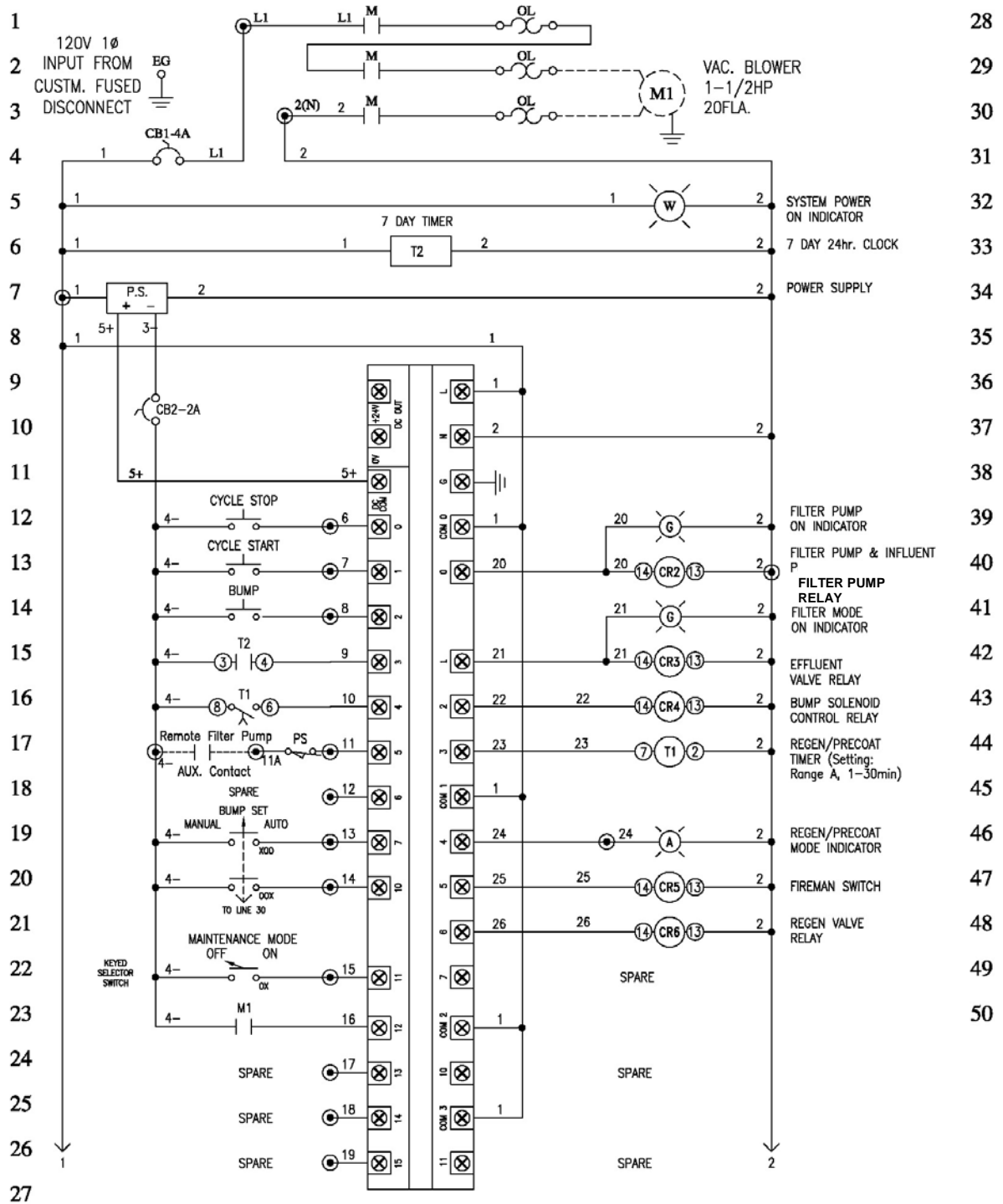

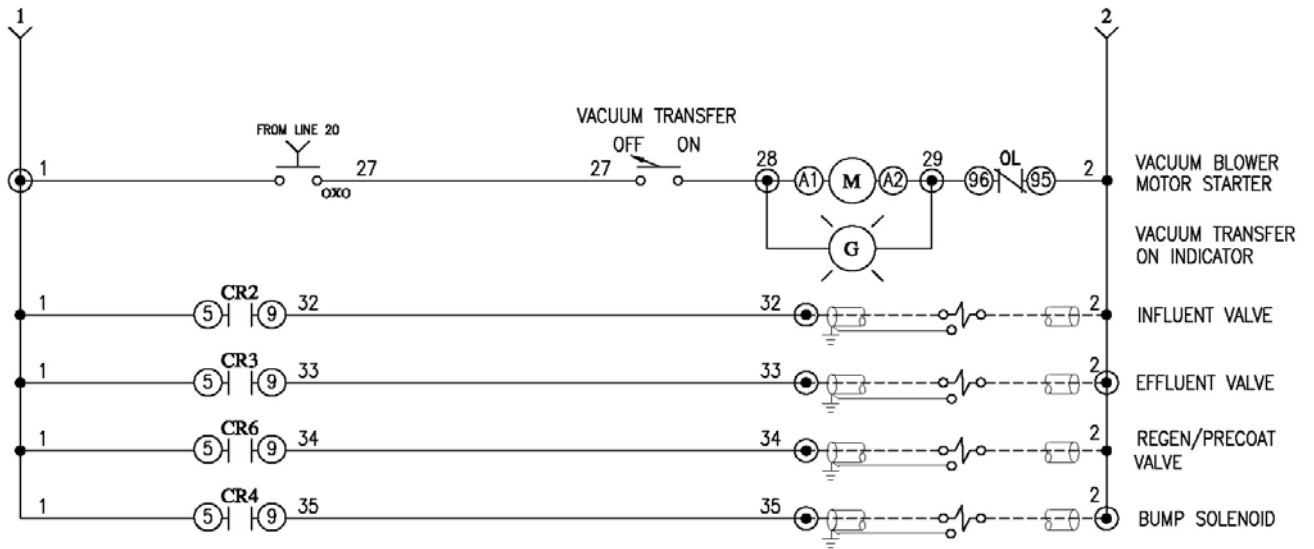

ALL RELAYS ARE ENERGIZED IN FILTER MODE

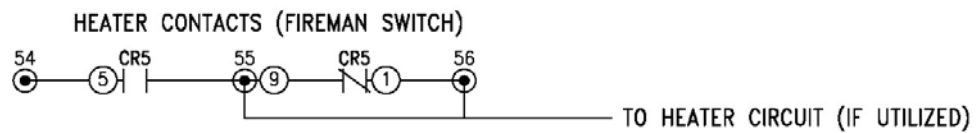
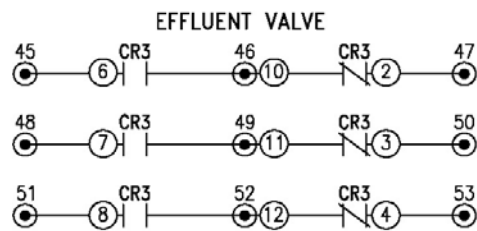
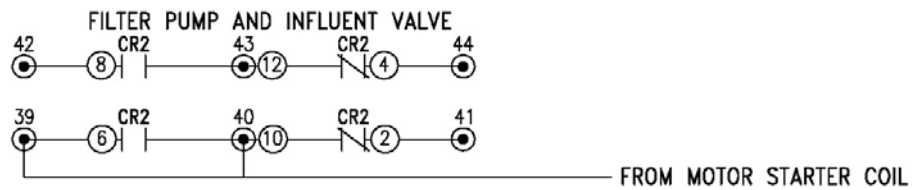

## BILL OF MATERIALS

QTY.	PART NUMBER	DESCRIPTION	MFG.
1	AM1868L	NEMA 4X Fiberglass enclosure 18x16x8"	ALL
1	P1868	Subpanel	HAM
1	FC4A-C24R2	PLC	Idec
1	PS5R-B24	24Vdc power supply	Idec
1	S201K4	CB1; 1P4A Circuit breaker	ABB
1	S201K2	CB2; 1P2A Circuit breaker	ABB
3	RH2B-ULAC-120V	CR 4, 5, 6: 120V 3P control relay	Idec
3	SH2B-05C	3P relay fingersafe socket	Idec
1	RH3B-ULAC-120V	CR2; 120V 4P control relay	Idec
1	SH3B-05C	4P relay fingersafe socket	Idec
1	RH4B-ULAC-120V	CR3; 120V 4P control relay	Idec
1	SH4B-05C	4P relay fingersafe socket	Idec
1	RTEP1-AF20	On delay timer	Idec
1	SR2P-05C	Timer fingersafe socket	Idec
1	E22H5X10	Power; White lens, light unit	CH
1	E22H9X10	Regen Mode; Amber lens, light unit	CH
3	E22H3X10	Green lens, light unit	CH
1	E22P1A	PB, black flush w/NO contact	CH
1	E22P3A	PB, green flush w/NO contact	CH
1	E22XG1	3 pos. sel sw	CH
1	E22X51A	2 pos. sel sw	CH
1	E22K52	2 pos. key sel sw	CH
2	E22B11	1 NO and 1 NC contact block	CH
1	E22B2	Contact block	CH
1	E22E2	PB, red ext.	CH
1	DIGI-20A-120	T2; 120Vac 7 day 24 hour timer	GRS
1	A26-30-10-84	Vac. Blower 1.5HP 120V contactor	ABB
1	TA25DU25	OL relay (18-25A)	ABB
1	E1SH90PLS	Pressure switch	Barksdale
1	P4ME2	Male elbow	NOV
1	K02H07-355	Male fitting	NOV
32	0115 116.07	Terminal block	ENT
1	0118 368.16	Terminal end section	ENT
13	0125 116.01	Terminal block blue	ENT
1	0128 368.10	Terminal end blue	ENT
3	0206 351.16	Terminal clamp	ENT
1	0233 000.01	Marker	ENT
1	0176 663.00	2 Pole Jumper	ENT
1	0113 003.10	Separator	ENT
1	0176 665.02	4 Pole Jumper	ENT
1	FPA0029B-120V	Air manifold assembly 120V	FA
1	PCG-1/2	1/2" Strain relief	Mencom
2	L-100	1/2" lock nut	Neer
1	4-14(63)	6-Ground bar	NSI

PLC Software: RMF-7-9-08.LDR

**RECIRCULATION PUMP MOTOR STARTER CONNECTIONS**

TERMINAL NUMBERS - 4,11 = TO AUX. CONTACT IN MOTOR STARTER THAT WILL CLOSE WHEN MOTOR IS STARTED.  
 TERMINAL NUMBERS - 39,40 = FROM MOTOR STARTER COIL.

**AC TERMINAL BLOCKS (32)**

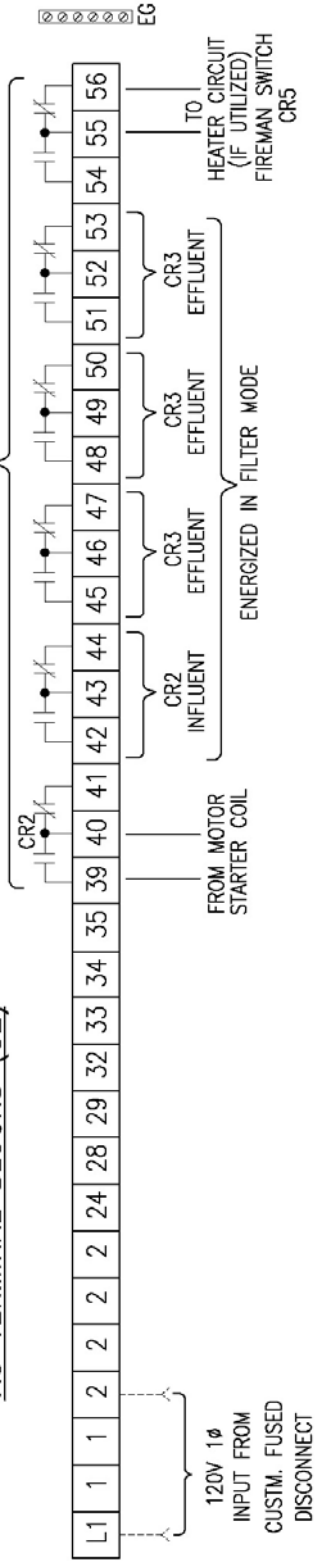

**DC TERMINAL BLOCKS (13)**

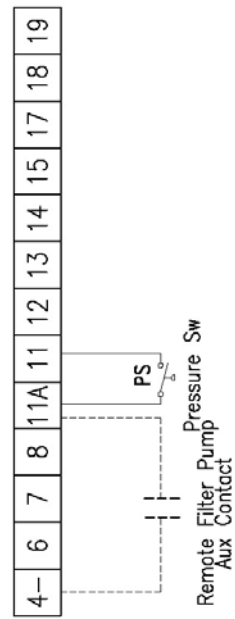



**RMF PROGRAMMER WIRING – 240V**

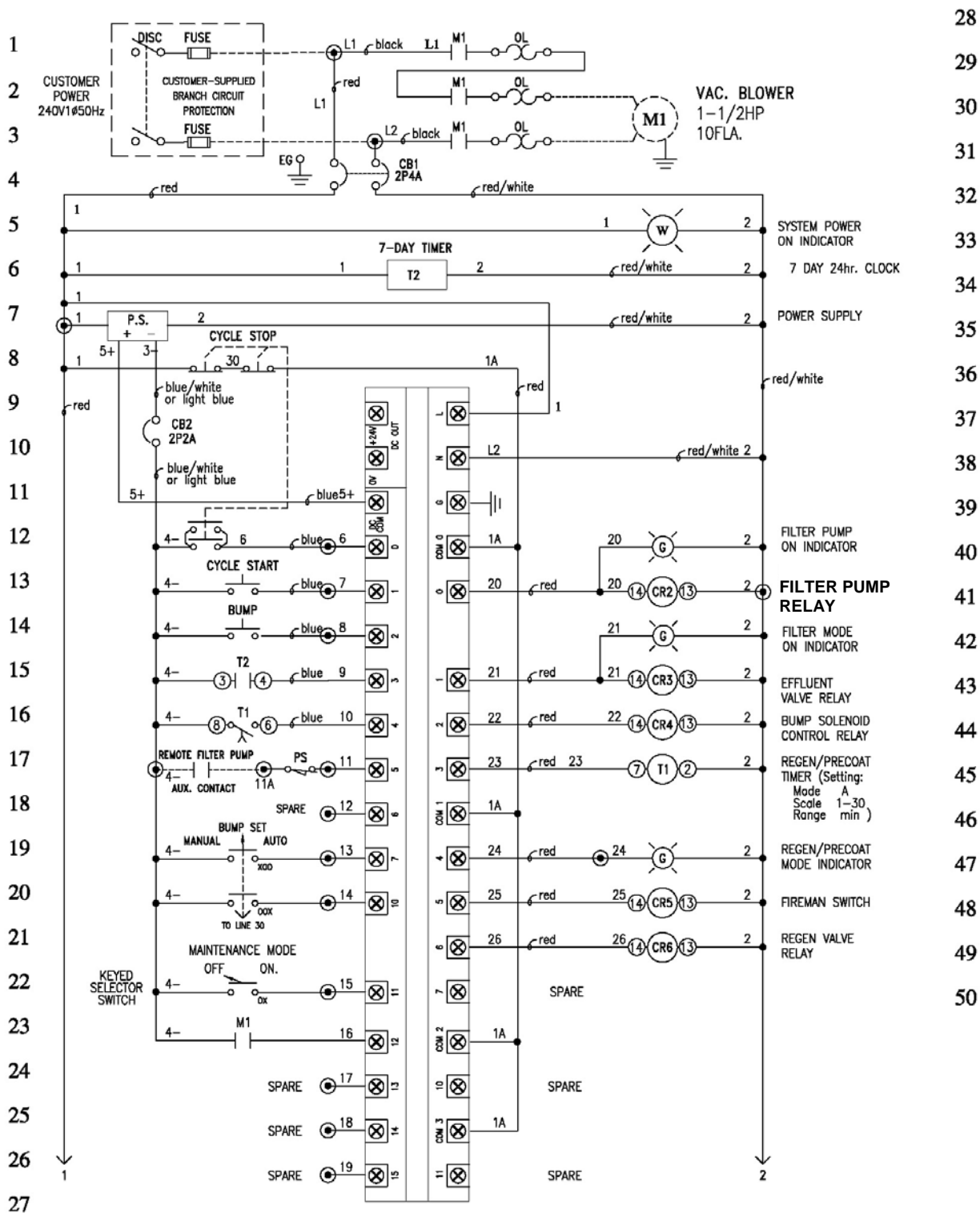

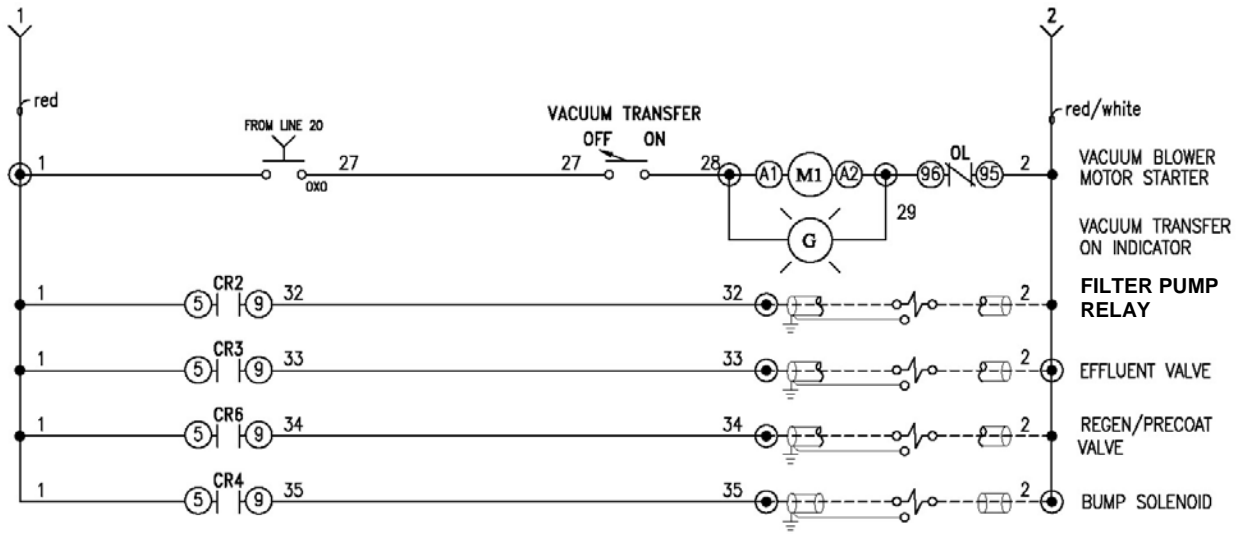

**FILTER PUMP**

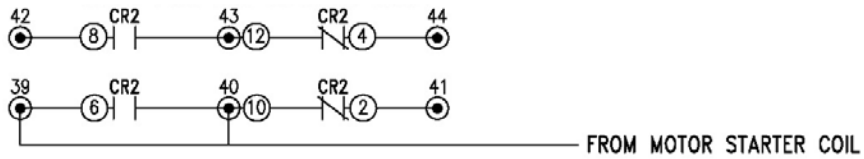

**EFFLUENT VALVE**

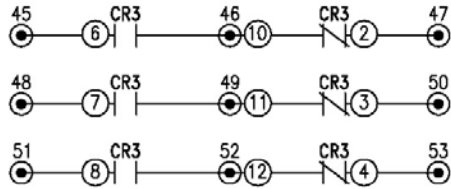

**HEATER CONTACTS (FIREMAN SWITCH)**

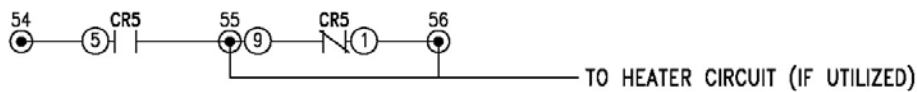

**NOTE:**

ALL WIRES SHALL BE EC APPROVED HAR TYPE.  
 PANEL WIRING COLOR CODE:  
 AC+DC POWER CIRCUITS      BLACK  
 AC CONTROL CIRCUIT        RED  
 DC CONTROL CIRCUITS      BLUE  
 GROUND                        GREEN/YELLOW  
 DRY CONTACTS TO EXTERNAL CIRCUITS      ORANGE

## BILL OF MATERIALS

QTY.	PART NUMBER	DESCRIPTION	MFG.
1	AM1868L	NEMA 4X Fiberglass enclosure 18x16x8"	ALL
1	P1868	Subpanel	HAM
1	A26-30-10-84	10 HP Motor starter	ABB
1	TA25DU11	OL relay (7.5-11A)	ABB
1	ZA40-80	240V contactor coil	ABB
1	S202K4	CB1; 2P4A Circuit breaker	ABB
1	S201K2	CB2; 1P2A Circuit breaker	ABB
1	FC4A-C24R2	PLC	Idec
1	PS5R-B24	24Vdc power supply	Idec
3	RH2B-ULAC-240V	CR, 4, 5, 6: 220V 2P control relay	Idec
3	SH2B-05C	2P relay socket fingersafe	Idec
1	RH3B-ULAC-240V	CR2: 220V 3P control relay	Idec
1	SH3B-05C	3P relay socket fingersafe	Idec
1	RH4B-ULAC-240V	CR3; 220V 4P control relay	Idec
1	SH4B-05C	4P relay socket	Idec
1	RTEP1-AF20	T1; 100-240Vac On delay timer	Idec
1	SR2P-05C	Timer socket	Idec
1	E22HV5	Power; lamp holder white lens	CH
4	E22HV3	Lamp holder green lens	CH
1	E22P7	PB, gray flush	CH
1	E22P3	PB, green flush	CH
5	B3080	240V lamp	MNL
2	E22V567	2 pos. select sw gray	CH
4	E22B2	Contact block 1NO	CH
1	E22VG7	3 Position select switch gray	CH
1	E22K52	2 pos. key sw	CH
4	E22B11	1 NO-1 NC contact block	CH
1	E22LL2	Cycle Stop; Push to operate, twist to release	CH
1	Digi20A-240 (Obsolete)	T2; 240Vac 7 day 24 hour timer(Obsolete)	GRS
1	E1SH90PLS	Pressure switch	Barksdale
1	L-100	1/2" lock nut	NEER
1	P4ME2	Male elbow	NOV
1	K02H07-355	Male fitting	NOV
33	0115 116.07	Terminal block	ENT
1	0118 368.16	Terminal end section	ENT
13	0125 116.01	Terminal block, blue	ENT
1	0128 368.10	Terminal end section, blue	ENT
3	0206 351.16	Terminal end clamp	ENT
1	0233 000.01	Marker	ENT
1	0176 663.00	2 Pole Jumper	ENT
1	0176 664.01	4 Pole Jumper	ENT
1	0113.003.10	Separator	ENT
1	FPA0029B-220	Air manifold assembly 220V	FA
1	HSK-K PG21 GRAU	Strain relief	Klemmbereich
1	2370.00	Lock nut	HEYCO
1	4-14(63)	6-Ground bar	NSI



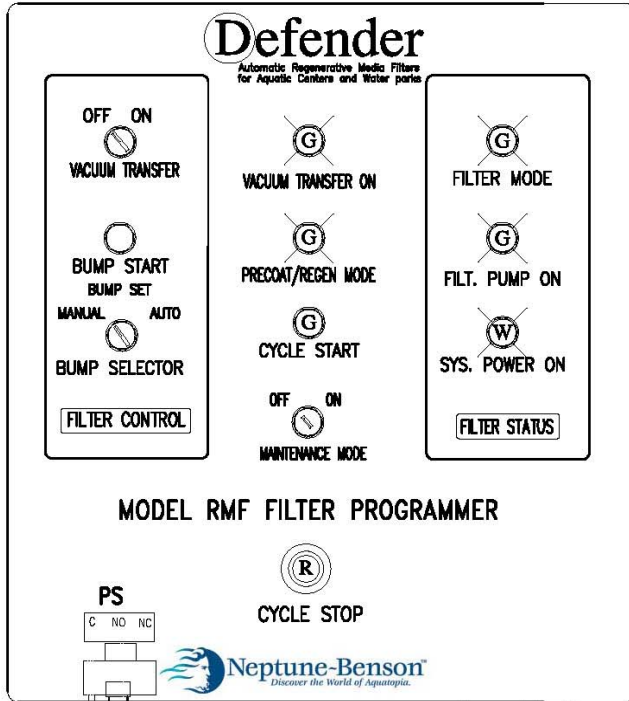

ENCLOSURE FRONT VIEW

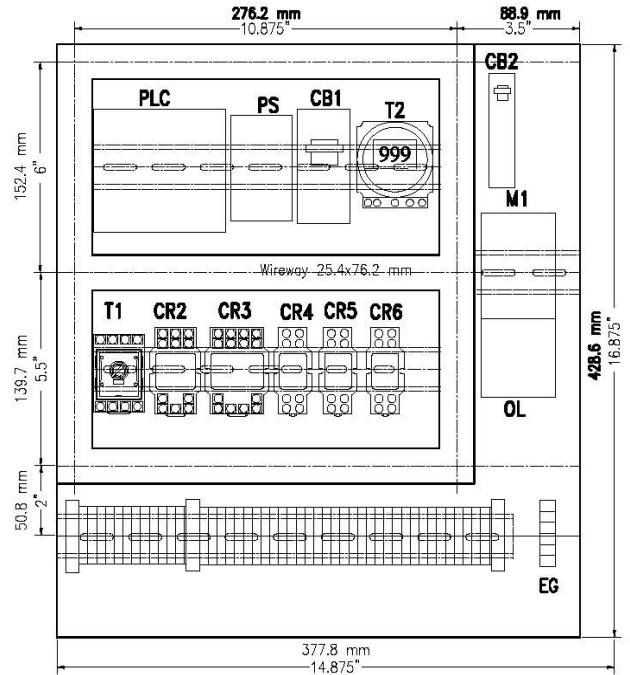

PANEL LAYOUT

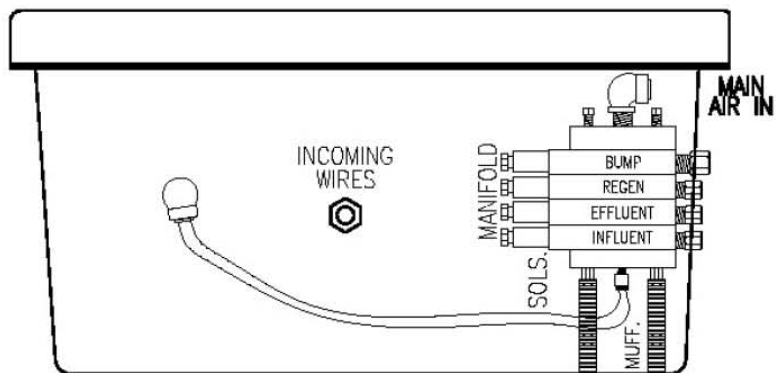

BOTTOM VIEW

RMF KONTROL BOKS & FILTER / REGULATOR

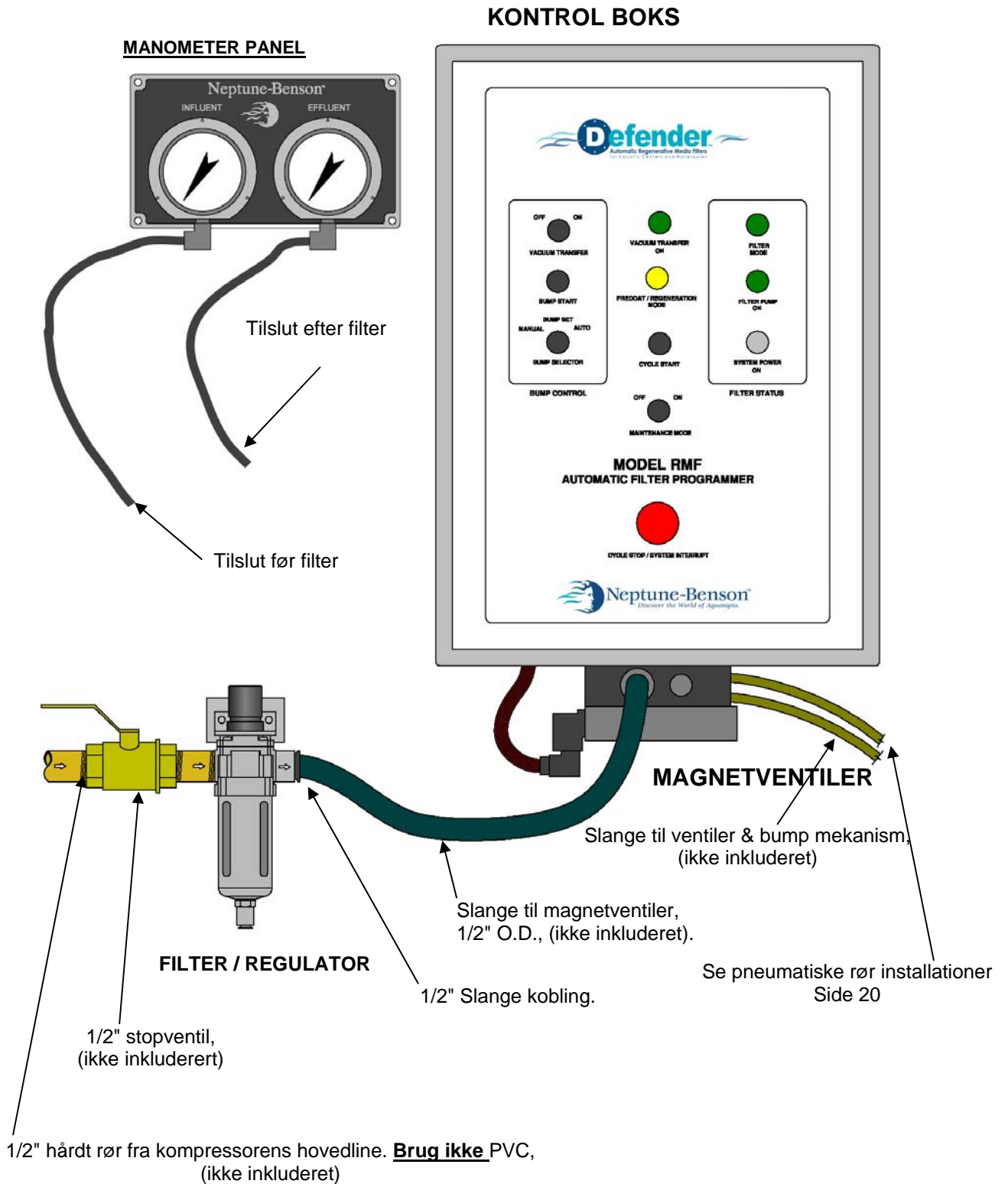



## KONTROL BOX



## PNEUMATISKE MAGNETVENTILER

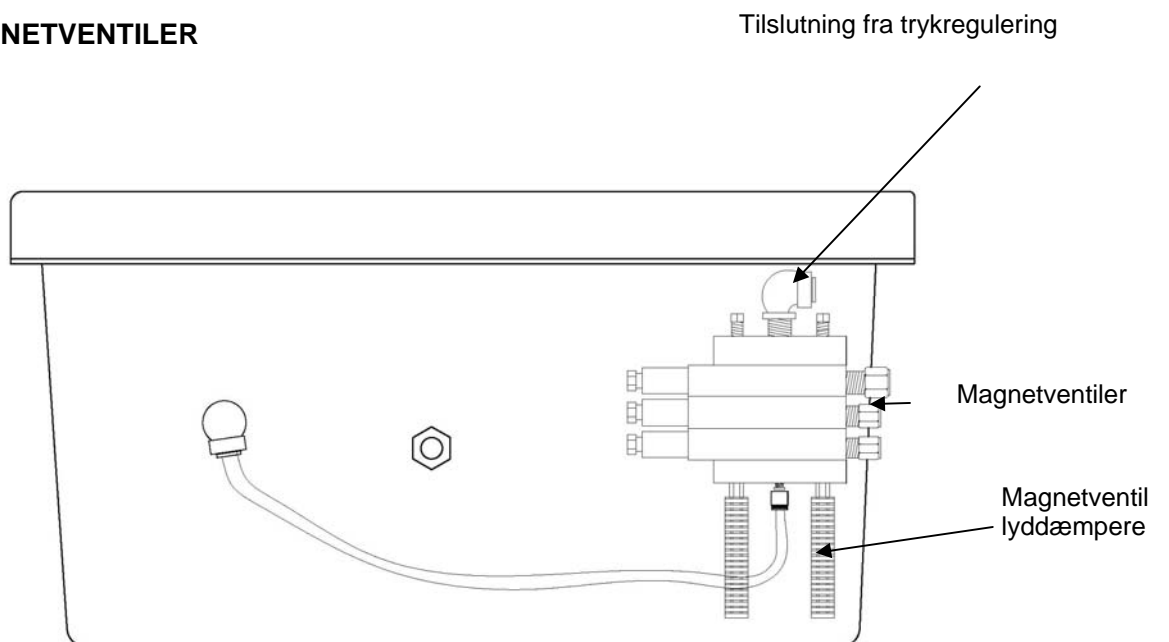

**PNEUMATISK MAGNETVENTIL FORBINDELSER**

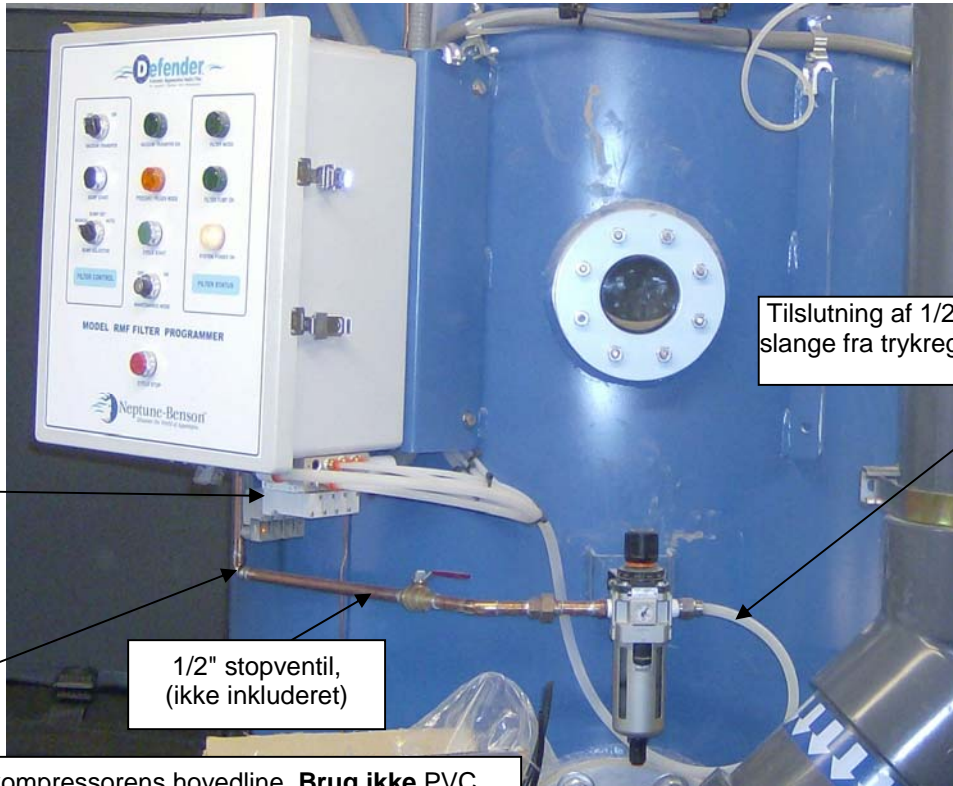

Magnetventiler

Tilslutning af 1/2" tryk slange fra trykregulering.

1/2" stopventil, (ikke inkluderet)

1/2" hårdt rør fra kompressorens hovedline. **Brug ikke** PVC, (ikke inkluderet)

**PNEUMATISK SETUP FOR VENTILHOVED**

Luft til ÅBEN Ventil

Luft til LUKKET Ventil

Ventil position indikator

Aktuator

Monter bolte på akuatoren som vist



## LUFTJUSTERING AF VENTILER

Rotations justering af aktuatorer er foretaget af fabrikanten. For yderligere Justering, følg disse instruktioner.

Advarsel! Installation, justering og vedligeholdelse skal ske i henhold til de sikkerhedsmæssige forhold. Tilslut ikke pneumatisk / elektrisk forbindelse, før alle operationer er afsluttet.

### Tilpasning i AFSLUTNING - 0 °

1. Skru counter-bolt og regulerings dyvel af på begge dæksler.
2. Slut luft fodring i port "A" for at have aktuatoren åben, Fig. 16.
3. Regulér rotation af aktuatoren i åbningen (90 °) på siden, ved at justere stempelets rejse gennem dets regulerings dyvel, Fig. 17.
4. Når det ønskede punkt i åbning er nået, hold regulerings dyvel i stilling og stram counter-bolt. Gentag denne drift på den anden side af aktuatoren, Fig. 18.
5. Slut pneumatisk / elektrisk fodring og kontroller korrekt arbejdsstilling.

### Tilpasning i ÅBNING - 90 °

1. Tag dækslerne af ved at løsne skruerne i den rækkefølge som angivet; træk fjedre ud, hvis der er nogen, fra stempel sæder, Fig. 11.
2. Skru counter-bolt og dyvel af for regulering af stemplets vandring fra begge sider af aktuator, Fig. 12.
3. Hold stænglen lidt i spænd, (ved at fastsætte centralen for kugleventiler og ved særlige dynamometriske nøgle til butterflyventiler) og regulér rotation af aktuatoren i afslutningen (0 °) på den ene side, juster stempelets rejse gennem regulering dyvel, Fig. 13.
4. Når det ønskede punkt lukning er nået, hold regulering dyvel i position, og stram counter-bolt. Gentag denne operation på den anden side af aktuatoren, Fig.14.
5. Sammel fjedrene hvis der er nogen, og monter ligeledes dækselsskruer, ved at skrue skruerne i lidt af gangen iht. nummerering, Fig. 11.
6. Tilslut pneumatisk / elektrisk fodring og kontroller korrekt funktion.

### BEMÆRK:

Hvis aktuatoren er monteret i "foretrukne" orientering, åbnings justeringen er på indersiden og lukke justering er på ydersiden.

### VÆRKTØJS STØRRELSER FOR JUSTERING AF DEFENDER PNEUMATISK AKTUATORER START / STOP FUNKTION.

AKTUATOR MODEL NR.	<u>UNBRAKONØGLE / TOPNØGLE</u>
CH75	4mm UNBRAKONØGLE / 13mm TOPNØGLE
CH85	4mm UNBRAKONØGLE / 13mm TOPNØGLE
CH100	5mm UNBRAKONØGLE / 17mm TOPNØGLE
CH125	6mm UNBRAKONØGLE / 19mm TOPNØGLE

### CYLINDER ENDER

AKTUATOR MODEL NR.	UMBRAKONØGLE
CH75	5mm
CH85	6mm
CH100	6mm
CH125	8mm

## PNEUMATISK RØR INSTALLATION

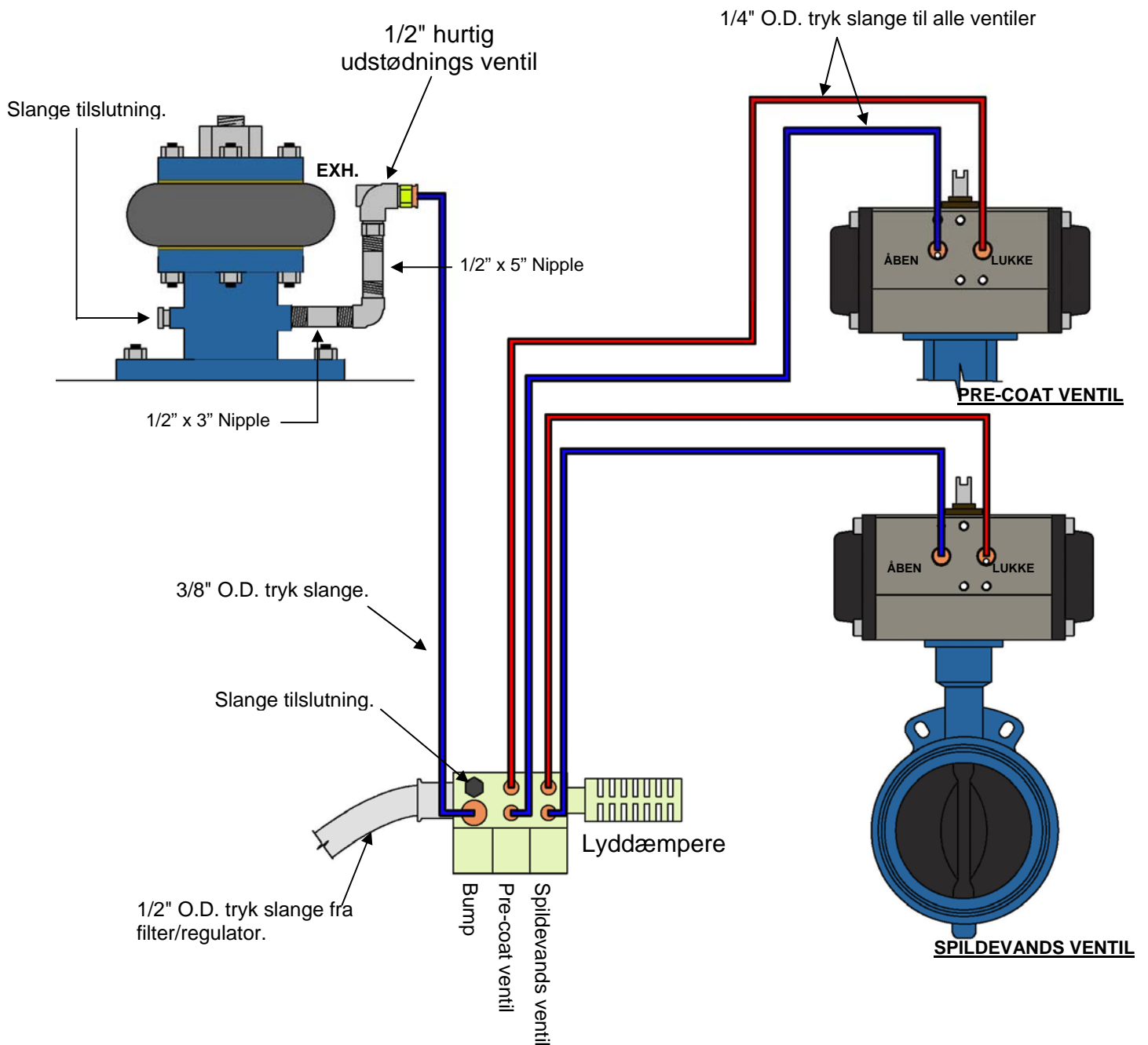

### MAGNETVENTILER

### SLANGE SETUP

#### **Bemærk!**

Rør leveres ikke.

## VAKUUM SYSTEM

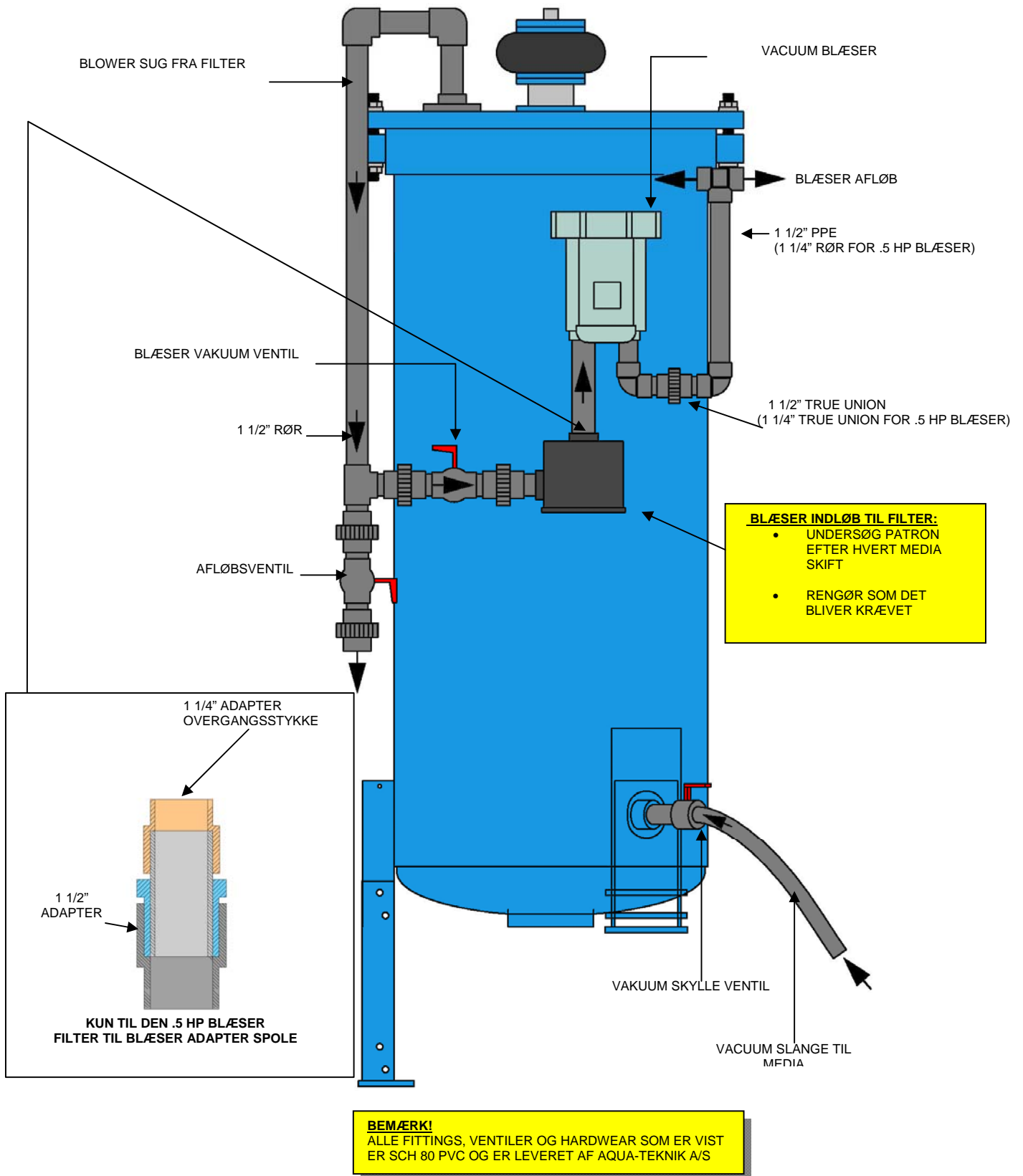

## VAKUUM SLANGE & FILTER JORDLEDNING

Installer vacuum skylleventil

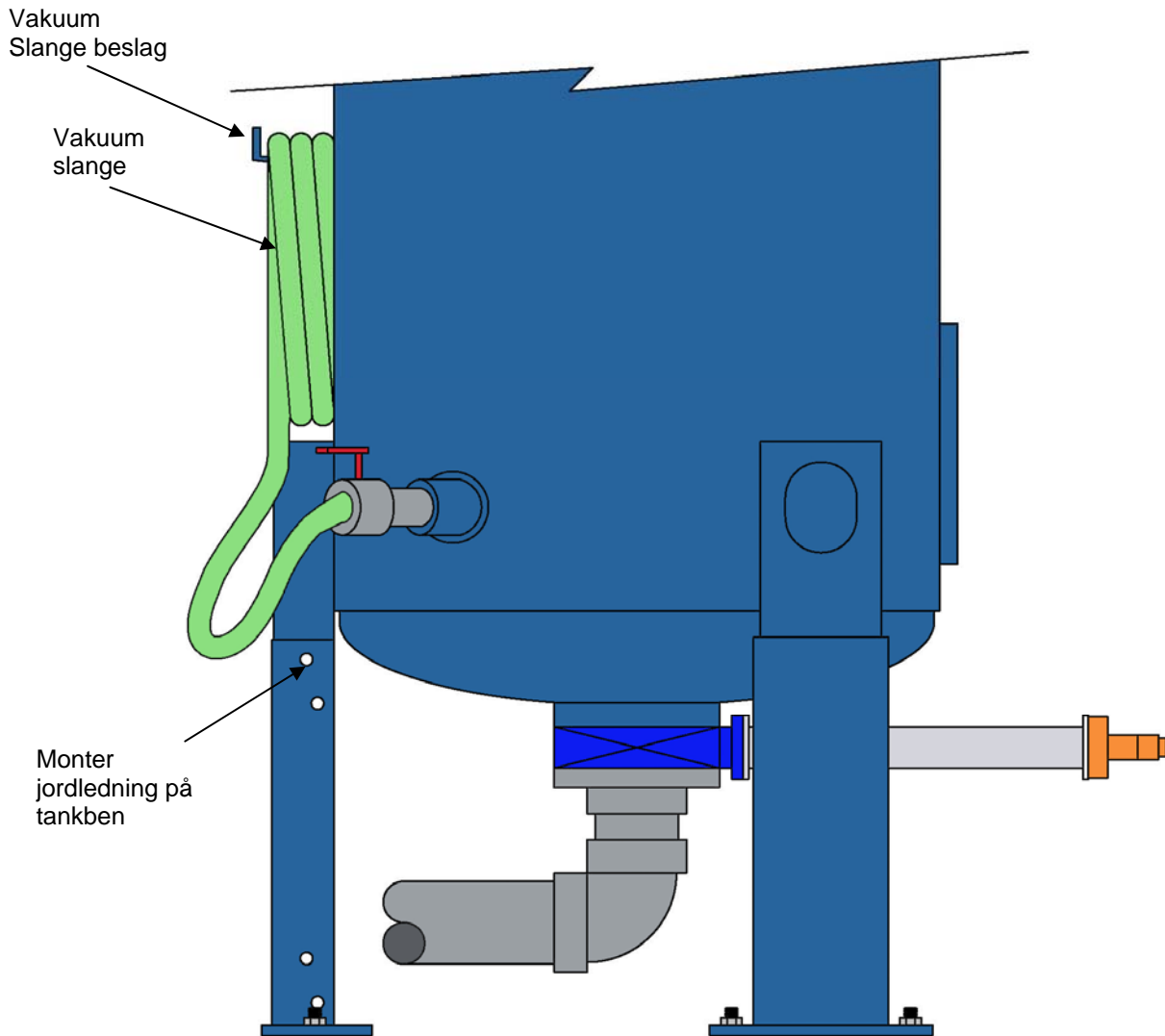

Filteret skal jorderes for at forhindre korrosion.



## DEFENDER AKTUATOR TILPASNINGER

Det anbefales at aktuatoren monteres "vinkelret" til rørsystemet

1. "Åbning" justering foretages på indersiden
2. "Lukning" justering foretages på ydersiden

Rotation mod uret for at lukke

### BEMÆRK!

Luft ind i venstre (med ansigtet rettet mod Flow control ventilerne) åbner ventilen og luft i den højre lukker ventilen.

**AKTUATOREN monteres "parallel" med rørene (VALGFRI)**

1. "Åbning" justering foretages på ydersiden
2. "Lukning" justering foretages på indersiden

Kør med uret for at lukke

### BEMÆRK!

Luft ind i højre (med ansigtet rettet mod Flow control ventilerne) åbner ventilen og luft ind i den venstre lukker ventilen.

## FLOW (SPEED) Reguleringsventiler

Den pneumatiske aktuatorer er forsynet med strøm reguleringsventiler. Disse bruges til at regulere hastigheden på drosselspjæld operationen.

1. Sluk lufttilførselen.
2. Fjern slangen fra den "Lukket" port i den pneumatiske aktuator (se pg. 22 for at afgøre, hvilken port der er den lukkede port) og forbind den til "Lufttilslutning ind" på luft kontakten.
3. Fjern slangen fra den "Åbne" port i den pneumatiske aktuator.
4. Tilslut slangen fra lufttilslutningen til begge porte i den pneumatiske aktuator. Åben lufttilførselen.
5. Flyt kontakten frem og tilbage for at kontrollere åbne og lukkede af ventilen.
6. For at justere, løsne låsemøtrikken og luk (med uret) for reguleringsventiler.
7. Åben (mod uret) 1.5 ture hver.
8. Reguleringsventilen på "Lukket" port regulerer butterfly ventilen "Åbning" hastighed. Reguleringsventilen på "Åben" port regulerer butterfly ventilen "Lukning" hastighed.
9. Lukning af ventilerne bremser hastigheden af butterfly ventilen. Åbning af ventilerne øger hastigheden af butterfly ventilen.
10. Juster om nødvendigt for en velfungerende gennemførelse.

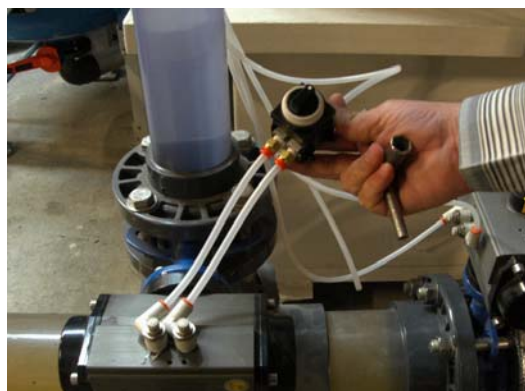

LUFT TILFØRSEL  
IND

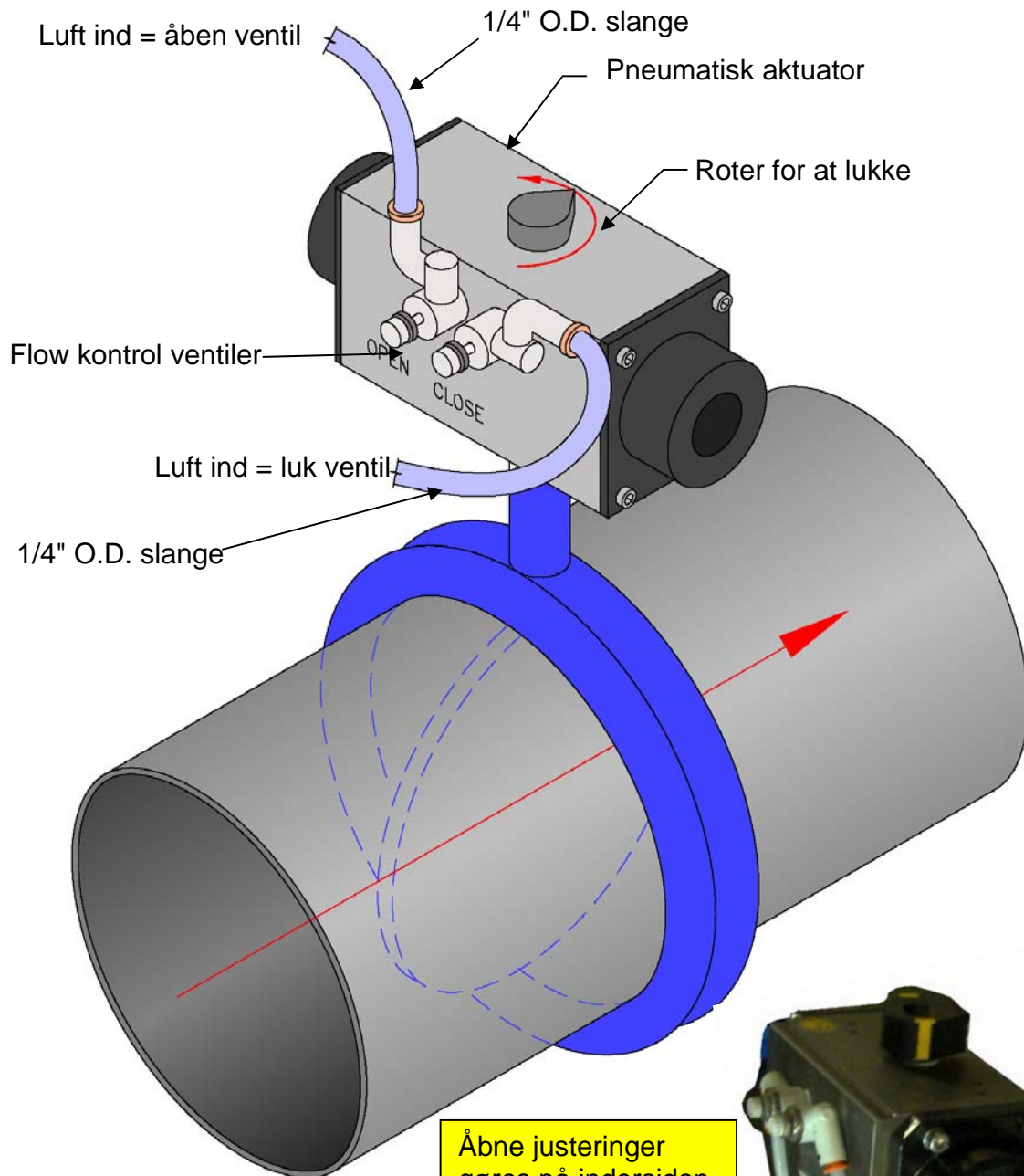

(FLOW CONTROL, ÅBNING, &amp; LUKNING)

VINKELRET MONTERING

Åbne justeringer  
gøres på indersiden  
af aktuatoren.

Lukke justeringer  
gøres på ydersiden  
af aktuatoren.

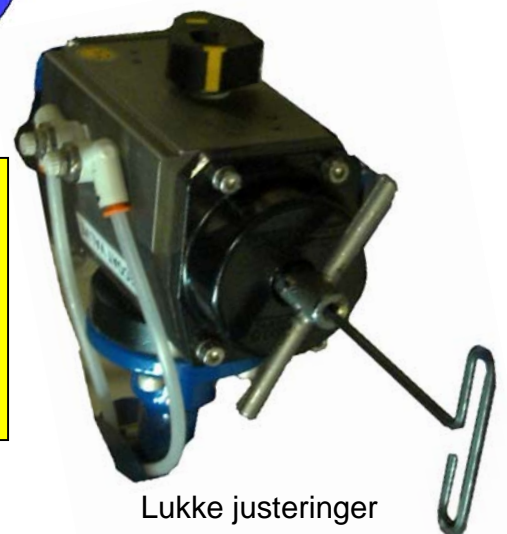

Lukke justeringer

**Bemærk:**  
**ANBEFALEDE MONTERING**

## PVC FLANGE INSTALLATION DATA

1. Follow illustrated bolt-tightening sequence.
2. Recommended gaskets: full face, 1/8" thick, elastomeric, 50-70 shore a hardness
3. Bolt threads should be well lubricated.
4. Always use full size flat washers with bolts and nuts.
5. Use primer and heavy-bodied PVC cement.

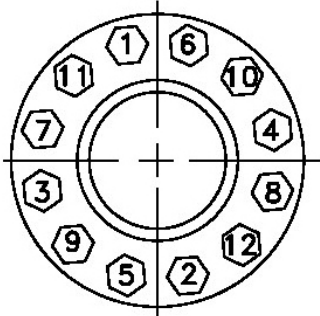
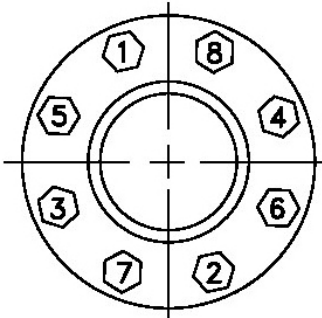
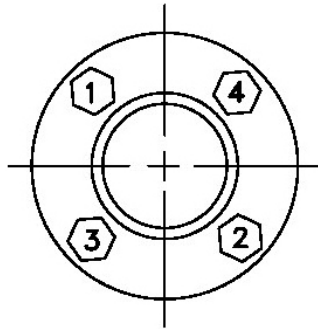

PIPING SIZE	BOLT CIRCLE DIAMETER	BOLT SIZE	RECOMMENDED TORQUE (FT./LBS.)
1/2"	2 3/8"	1/2"-13UNC	15 - 20
3/4"	2 3/4"	1/2"-13UNC	15 - 20
1"	3 1/8"	1/2"-13UNC	15 - 20
1 1/2"	3 1/2"	1/2"-13UNC	15 - 20
1 1/2"	3 7/8"	1/2"-13UNC	15 - 20
2"	4 3/4"	5/8"-11UNC	20 - 30
2 1/2"	5 1/2"	5/8"-11UNC	20 - 30
3"	6"	5/8"-11UNC	20 - 30

PIPING SIZE	BOLT CIRCLE DIAMETER	BOLT SIZE	RECOMMENDED TORQUE (FT./LBS.)
4"	7 1/2"	5/8"-11UNC	20 - 30
5"	8 1/2"	5/8"-11UNC	25 - 35
6"	9 1/2"	3/4"-10UNC	33 - 50
8"	11 3/4"	3/4"-10UNC	33 - 50

PIPING SIZE	BOLT CIRCLE DIAMETER	BOLT SIZE	RECOMMENDED TORQUE (FT./LBS.)
10"	14 1/4"	7/8"-9UNC	53 - 75
12"	17"	7/8"-9UNC	53 - 75

### NOTE!

Flanges conform to ANSI B16.5, class 150. Socket diameters conform to ASTM D 2467. Recommended working pressure: 150 PSI at 73.4°F.

**INSTALLATION AF BUTTERFLY VENTILER**

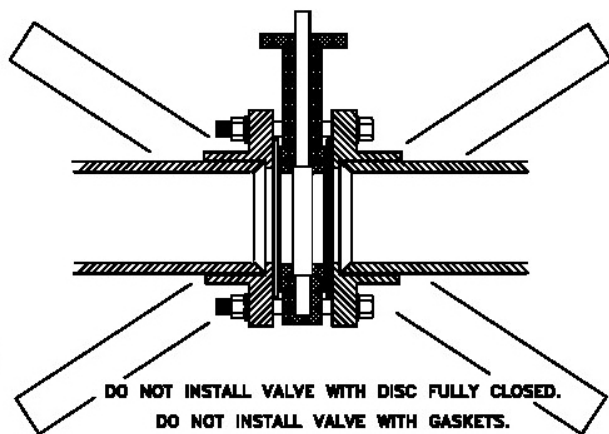
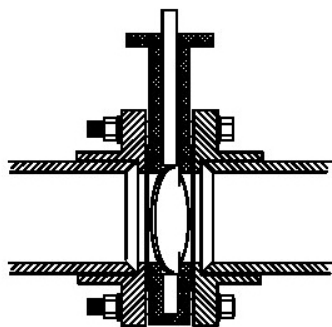
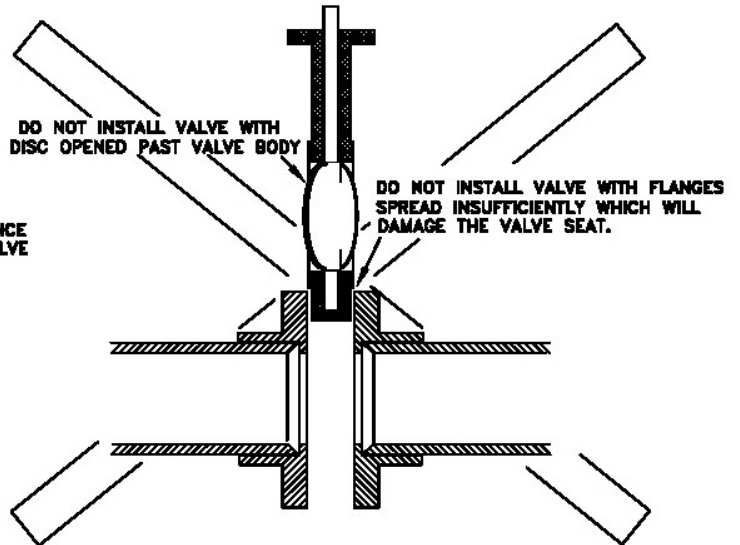
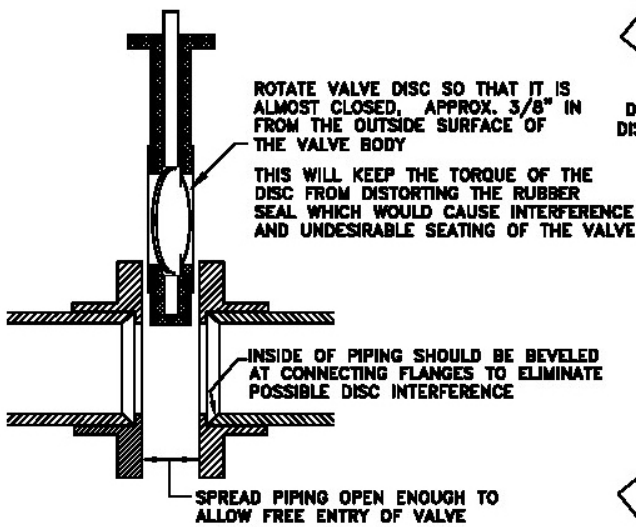

INSERT THE VALVE BETWEEN THE FLANGES AND ASSEMBLE THE VALVE TO THE FLANGES WITH ALL THE REQUIRED BOLTS.  
**DO NOT USE GASKETS WITH BUTTERFLY VALVES.**  
**DO NOT FULLY TIGHTEN BOLTS AT THIS TIME.**

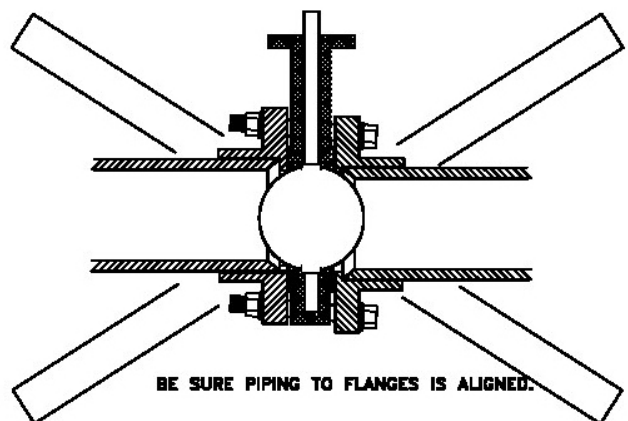
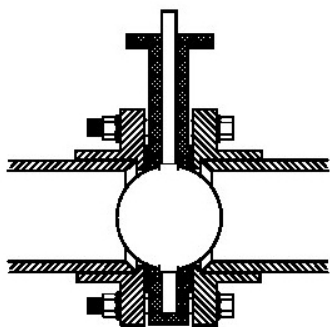

TURN THE DISC TO THE FULLY OPEN POSITION AND CENTER THE VALVE WITHIN THE FLANGES AND HAND TIGHTEN THE BOLTS.  
 SLOWLY CLOSE THE VALVE TO CHECK FOR ADEQUATE DISC CLEARANCE  
 RETURN THE DISC TO THE FULLY OPEN POSITION AND FULLY TIGHTEN ALL BOLTS.

**BE SURE PIPING TO FLANGES IS ALIGNED.**





## BUTTERFLY VENTILER

If your Neptune-Benson filter was factory furnished with face piping, standard butterfly valves are Dominion™ with nylon coated cast aluminum body, nylon coated ductile iron disc with stainless steel stems or Viceroy™ with all PVC construction with stainless steel stems. Regardless of construction, service and inspection of valves remains the same.

Butterfly valves have bushings around the handle shaft to keep the water from leaking out of the shaft. As the valve ages, the bushing tends to dry out. The dryness, combined with dust and dirt, inhibits valve operation and increases the force required to turn the valve handle. This is not a great problem when the valves are individually operated until the situation gets progressively worse and too great a force is required to turn the valve handle. If the filter valves have a linkage, the four valves with increased torque requirements can restrict the action of an automatic actuator as well as manual operation with the linkage handle. If the valve resistance is too great, an actuator can develop enough torque to shear the valve stem.

Routine preventive maintenance for these valves, without removing the valves, is to lubricate the stem and bushing with a food grade, silicone base, penetrating lubricant. The valve handle or gear operator will have to be removed to expose the shaft and bushing.

The valves are highly corrosion resistant and should provide satisfactory service for many years. It is possible, however, for these valves to become coated with foreign material due to an imbalance of the water chemistry, hair, lint or other material, which can wrap itself around the valve stems.

If your system consists of individual valves that are operated individually with a latchlock handle, ease of operation can be verified by turning the valve from fully open to fully closed. The resilient valve lining will be in contact with the valve disc before reaching the fully closed position. If, when closing the valve, you encounter resistance before reaching the 8th or 9th notch, or if operating the valve in either direction becomes difficult; inspection of the valve is recommended.

If you are inspecting one valve, it will be necessary to remove most of the securing bolts at that valve. The resilient lining provides the seal between the valve and the flanges so that no gaskets are required. The flanges must be opened or spread slightly so the valve may slide out of position. Be sure the valve disc is in the closed position before attempting removal.

Particular attention should be paid to the backwash valve or the valve connected to the waste line. This valve is more difficult to maintain since one side is exposed to an open line to atmosphere. This condition speeds up corrosion, coating and breakdown.

If you are inspecting all valves of a filter with a valve linkage (manual or automatic) it might be easier to disengage the whole assembly to facilitate individual valve removal.

To check the individual valves of a filter with a valve linkage, it will be necessary to disconnect the bolt or pin connecting the clevis arm to the linkage shaft. With the pin removed, the clevis arm can be used as a handle to check freedom of operation.

The valve shaft is round with two flat surfaces that indicate the position of the valve disc. If the flat surfaces run in the same direction of the piping (parallel) the disc is in the open position. If the flat surfaces are perpendicular to the piping, the disc is closed. Remember that the disc need not be 100% closed for shut-off purposes. The flats on the shaft, therefore, should not be a total 90 perpendicular; rather it should be a few degrees away from 90. If too much pressure is applied, it is possible to pass beyond the closed position. If this does happen, the valve lining will allow you to reposition the disc to the proper orientation with no harm to the valve.

The resilient lining of the valve provides a seal between the process water and the stainless steel shaft. If the position of the lining is altered due to coating or buildup of scale, etc., this seal could be broken. If the valve resists turning after cleaning, lubricate the shaft ends from the inside and outside. If your service schedule includes removal of the valves for inspection, the resilient lining should be coated with the same lubricant.

If the valve disc does not move freely with normal pressure after treating with the lubricant, you should consider replacing the valve. Replacement valves are not expensive and usually cost less than the labor and replacement parts required to repair an existing valve. If your filter room is particularly damp and prone to corrosion, you should consider using a valve with a nylon coated body if you plan to replace the valves. They are directly replaceable with the standard coated valves and will resist corrosion for a much longer period of time.

In most cases, Neptune-Benson maintains a folder that will identify your equipment provided. If you plan to order replacement valves from Neptune, the process can be expedited by noting the shaft configuration (dimensions) of your present valves as well as the face to face dimension of the mounting flanges that sandwich the valve. Valves can be shipped via UPS promptly at your request.

## PRESSURE GAUGES

All Neptune-Benson supplied gauges are designed with dampening orifice openings to minimize possible damage due to surges or quick changes in pressure. The small opening is therefore subject to clogging, especially those gauges located before the filter.

If a gauge reacts slowly to changes in pressure or has a tendency to remain at an elevated pressure while the system is shut down, remove the gauge for inspection. The opening or orifice is located within the center inside the nozzle connection. If you can not observe an opening somewhat smaller than a pinhead, the gauge should be cleaned or replaced.

Switching the positions of gauges will verify operation of a gauge and should indicate if any gauge requires repair or replacement. All gauges are provided with 1/4" mnpt connections. It is recommended that a gauge cock be installed at each gauge.

Remember that the gauges in your system provide you with the best data relative to the operation and efficiency of items of equipment. If you keep them in good order, they will help make your daily chores less troublesome.

Do not disregard them when the break down for replacement gauges are inexpensive and easy to replace.

## SUPPORT SPACING FOR PVC

Support and spacing requirements for PVC pipe, fittings, and valves should be designed into the system to allow for increased temperature. As temperature increases, the tensile strength of PVC decreases, so the pipe and associated fixtures must be well supported.

Horizontal piping systems should be supported on uniform centers, which are determined by maximum operating temperature. The following chart shows the recommended support spacing according to size, schedule, and operating temperature when the transported liquid has a specific gravity of up to 1.35 with no concentrated loads ( $1.35 \times 62.4 \text{ lbs.} = 84 \text{ lbs/ft}^3$  of specific weight). These spacings apply to uninsulated lines, either in a building or exposed to the atmosphere. The formula used to determine the spacing data takes into account the heating effect of the sun on low temperature lines. For insulated lines, it will be necessary to reduce spans by 30% to allow for the additional weight of the insulation.

Adjustable clevis, ring, or roll hangers and roll stands with broad support surfaces are best for use with PVC pipe. Other suitable types include; pipe clamps, straps, and riser clamps. The broader and flatter the support surface, the better. They should be filed smooth, taped, or padded to avoid the possibility of damaging the pipe. Also remove any sharp edges or burrs on the clamps, anchors, or any other supporting equipment that could frequently come in contact with the pipe. Anchor the pipe so that it is held absolutely rigid or constricted. Some slight axial movement is necessary.

For vertical lines, it is recommended that the pipe be banded at the intervals determined by the vertical load involved. Riser clamps are best utilized if they are supported on spring hangers. Short risers should include a saddle at the bottom and may require an additional hanger at the top. Longer risers may require over-sized U-bolts or similar devices to prevent lateral motion.

All valves and points of concentrated loads such as tees and flanges should have support independent of normal span support. Metallic or lined valves should be fully supported because of the increased weight. At higher temperatures or when the line is transporting hazardous liquids, it may be economically more practical to use a continuous support system.

When pipe clamps are used, they should not force the pipe and fitting into position. To remedy this, each section of the

pipeline should be laid out and all connections, whether solvent cemented, screwed, or flanged should be made while the pipe is held in temporary support. Once the joints have been completed, the final clamping can be done. When correctly installed, a clamp, a holder, or a pipe connection can be loosened or removed without the pipeline shifting position.



## RECOMMENDED SUPPORT SPACING (IN FEET)

NO M. PIP E SIZ E	PVC PIPE								CPVC PIPE			
	SCHEDULE 40				SCHEDULE 80				SCHEDULE 80			
	TEMP. °F				TEMP. °F				TEMP. °F			
	60	80	100	120	60	80	100	120	60	80	100	120
1"	5.5	5	4.5	3	6	5.5	5	3.5	6.5	6.5	6	5
2"	6	5.5	5	3.5	7	6.5	6	4	7.5	7.5	7	6
3"	7	7	6	4	8	7.5	7	4.5	8.5	8	7.5	4.5
4"	7.5	7	6.5	4.5	9	8.5	7.5	5	9.5	8	8	5
6"	8.5	8	7.5	5	10	9.5	9	6				
8"	9	8.5	8	5	11	10. 5	9.5	6.5				
10"	10	9	8.5	5.5	12	11	10	7				
12"	11. 5	10. 5	9.5	6.5	12	11	10	7				

## OPERATION

### PRE START- UP CHECK

1. For at forhindre eventuelle skadelige trykstød, kræves det, at en VFD (Variable Frequency Drive) eller en "Soft Start "Motor Starter anvendes til cirkulationspumpe.
  - Indstil start rampe til mellem 10 - 30 sekunder.
  - **Vigtigt!** Sæt stop rampe til "0" sekunder for at forhindre resterende pres i filteret.
2. Brug jern eller galvaniseret rør (IKKE PVC) fra kompressoren op til filteret / regulator monteret på Defender tanken. Tilføj en ventil til at isolere lige før filter / regulator. (Se side 12)
3. Alle rørtilslutninger skal installeres på Defender Regenerativ Media Filter Skematisk. (Se næste side). En vandudskiller med automatisk dræn skal installeres som vist på side 1. En model AMG350-N04D anbefales.
4. Kritiske elementer til kontrol forud for planlægning start-up:
  - Power up alle systemkomponenter:
    - A. Kompressor
    - B. RMF Programmør
    - C. Vacuum Transfer Motor
  - Sæt trykregulator til 90 PSI.

### TØR AFPRØVNING

- Kontroller for utætheder på rør forbindelserne. Hvis der forekommer utætheder sluk for kompressoren. Fjern rørene og kontroller, om rørene er skåret lige. Udbedre eventuelle fejl på rørene. Indsæt rørene igen, sikre at det er i fuld gang. Træk i rørene for at være sikker på at de er tilsluttet sikkert. Hvis utætheder stadig forekommer, kan rørene være de forkerte OD (Outside diameter). Alle rør skal være Britisk standard.25 " , .375" og .50 "OD som vist på tegningen.
- Kontroller rotation af cirkulationspumpe motoren. (Luft skal strømme ud af t-stykket)
- Sæt Motor Starteren på afbryd "OFF".
- Installer lus mellem # 4 & # 11 på slutblokken. (For at simulere at pumpen er i funktion)
- Sikre at Bump er sat til manuel, og vedligeholdelse (maintenance) er sat til OFF position.
- Tryk på Cycle Start. Precoat lampe lyser. Tilløbs ventilen åbnes. Precoat ventil åbner om 60 sekunder.
- Efter 10 minutter, lyser filter lampe og indløbsventilen åbner. Precoat ventilen lukker, og systemet vil være i Filter Mode.

### BEMÆRK:

- Efter tør prøve, fjern lus mellem # 4 og # 11.

Be sure to run controller wiring from Filter Pump motor starter (soft start or VFD) to auxillary contact to 4 and 11A for run confirm function.

## QUICK START INSTRUKTION

Når du har færdig gjort dine indledende forberedelser, vil du nu være klar til at starte filteret op. For at starte korrekt op, skal systemet være helt lukket ned, med alle pumper og filter operationer låst ude.

### Krav:

- passende mængde af medie
  - o Særlige filter krav vil blive placeret på datapladen nær filter kontrolpanelet
- Vandforsyning
- Luft forsyning
  - o Luft trykket bør være minimum 90psi

### **BEMÆRK!**

**Defender filtre er konstrueret til at fungere med Aqualite eller Diatoméjord. Ved brug af andre produkter vil man ikke få det optimale ud af filtret!**

### **BEMÆRK!**

**Tænd ikke for vacuum overførsel før filteret er drænet!**

## PÅFYLDNING AF MEDIE I SYSTEMET - VACUM OVERFØRSEL

### **BEMÆRK!**

**Tanken skal være tom!**

1. Passende mængde af medie er placeret på filtre data pladen ved siden af filter kontrolpanelet.
2. Åbn vakuum aftapningsventil for at dræne vand i vakuum overførsels rørledningerne.
3. Luk vakuum aftapningsventil, åben vakuum overførsels ventil og vakuum slange ventil. Kontroller tank dræn og system ventiler er lukket.
4. Drej bump omskifter til bump sæt.
5. Drej vakuum overførsels kontakten til on og vakuum den nødvendige mængde af medie ind i filter tanken.
6. Drej vakuum overførsels kontakten til off, luk vakuum slange ventil og vakuum overførsels ventil, åbent precoat udluftning linje og vakuum dræn linje.
7. Drej bump omskifter til manuel.
8. Luk afløbs reguleringsventilen. Tryk på cyklus start-knappen og åben langsomt reguleringsventilen for at fylde filteret med vand.
9. Når filteret er fyldt, og al luft er ventilerede fra filteret, luk for precoat udluftnings linjen og vakuum dræn linje ventilerne. Filteret vil automatisk gå til filter mode (cyklus start) efter pre-coat.

### **BEMÆRK!**

**Efter vakuum overførsel af medie er komplet og cyklus starter er trykket, vil precoat ventilen have en 60 sekunder forsinkelse, før åbning. Dette giver systemet mulighed for at udlufte fanget luft. Under en normal bump cyklus, vil precoat ventilen have en 5 sekunders forsinkelse umiddelbart efter bumpet.**

### **BEMÆRK!**

**Ved den første filter opstart, dræn og genfyld med medie, så snart bassin vandet er klart. Dette er nødvendigt for at fjerne produktionsrester, gentag processen hvis bassin spæde vandet er meget snavset, dræn og genopfyld medie.**

## CYCLE START

1. Tryk cycle stop.
2. Drej bump omskifteren til manuel eller automatisk, og tryk på cycle start-knappen.
3. Det første trin i filtrering cycle er precoat tilstand, systemet vil fortsætte på denne cyklus ti (10) minutter. Check visnings vindue, og hvor lang tid det tager skueglasset at blive klart. Dette er systemets nødvendige precoat tid.
4. Når precoat tilstand er afsluttet, vil filteret gå til filter mode. Spildevandsventilen til bassinet vil åbne, efterfulgt af lukningen af precoat ventilen. Filteret tager nu vand ind fra bassinet, behandler det gennem filter systemet, og returnere det tilbage i bassinet.
  - På dette punkt, vil du ønsker at undersøge og registrere filterets tryk. Dette er systemets oprindelige differential tryk.
5. Filteret vil fortsætte i filter-mode for det præ-programmerede interval(se side 52 for programmering af uret), eller hvis den står i manuel drift, vil den fortsætte indtil bump start-knappen er trykket. Afhængig af bade belastningen, anbefales det, at et bump skal udføres hver dag.
6. Når bump start-knappen er trykket, eller aktiveret af uret, vil filteret gå i regenererings tilstand. Den automatiserede controller vil stoppe pumpen, både Indløbs ventilen og spildevands ventilen lukkes.
7. På dette tidspunkt aktiveres bump mekanisme. Det vil bumpe op og ned 10 gange. Denne handling adskiller mediet fra rørene.
8. Systemet vil derefter automatisk gå i precoat tilstand som beskrevet ovenfor, og begynder at cycle igen.

## GENOPFYLDNING AF MEDIE

Der er flere tegn som kan gøre dig opmærksom på hvornår det er tid til genopfyldning af medie:

1. Igen, afhængig af badende belastning, kan mediet kræve genopfyldning om 3 uger eller 2-3 måneder. Når du betjener systemet, vil det vise sig, når mediet kræver genopfyldning.

- o Hvis trykforskellen forbliver på 10 til 12 PSI snart efter bumping.
- o Hvis systemet flowhastighed, ikke kan opretholdes.
- o Hvis medierne ikke opløses og fortsat er klumpet.

### FORSIGTIG

**Maksimal differensial driftstryk  
må ikke overstige 15 PSI. Overstigning  
af dette tryk kan  
medføre beskadigelse.**

2. Før tryk på cycle stop, åben aftapningsventil delvist for at fjerne eventuelle rester i røret.
  - A. Under forudsætning af ovenstående har fundet sted, tryk på cycle stop-knappen. Pumpen stopper, og ventilerne lukker.
  - B. For at genoplade mediet, drej bump omskifter til bump sæt.
  - C. Bump filteret cirka fem (5) gange ved manuelt at trykke på knappen bump. Dette vil fjerne filterkager fra rørene.
  - D. Åbn aftapningsventil i bunden af filteret.
  - E. Åbn vakuum aftapningsventil. (For at øge drænings tilløb)
  - F. Når tanken er helt tømt, dreje vakuum overførsel knappen over på On, så Off. Dette vil få Precoat ventilen tilbage til standard, til de 60 sekunders forsinkelses funktion.
  - G. Genopfyld tanken med vand og gentage trin C, D & E
  - H. Gå retur til Quick start instruktion på side 33, for at få filtret tilbage til service..

### Gå retur til Operations mode, hvis cirkulationspumpen stopper

1. Tryk Cycle Stop.
2. Tryk Cycle Start - Defaults  
Til Precoat

# ILLUSTRATED OPERATING MANUAL



## Media Charging

1. Be sure tank is completely drained before turning on vacuum transfer.
2. Confirm all valves are Closed before start. **Be sure pump discharge valve is closed!**
3. Turn Bump Selector switch to Bump Set to prepare for Vacuum Transfer

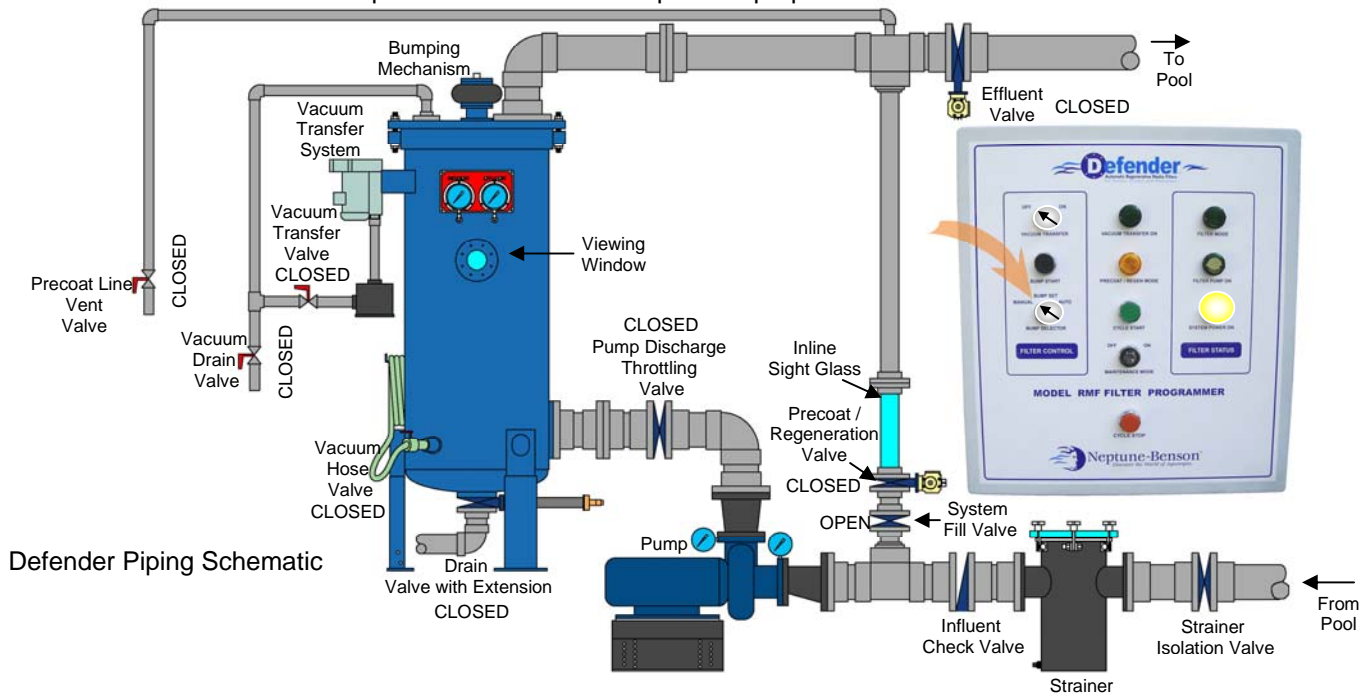

4. Get appropriate amount of media for transfer.
5. Open Vacuum Transfer Valve.
6. Open Vacuum Hose Valve.
7. Turn the Vacuum Transfer Switch to on.

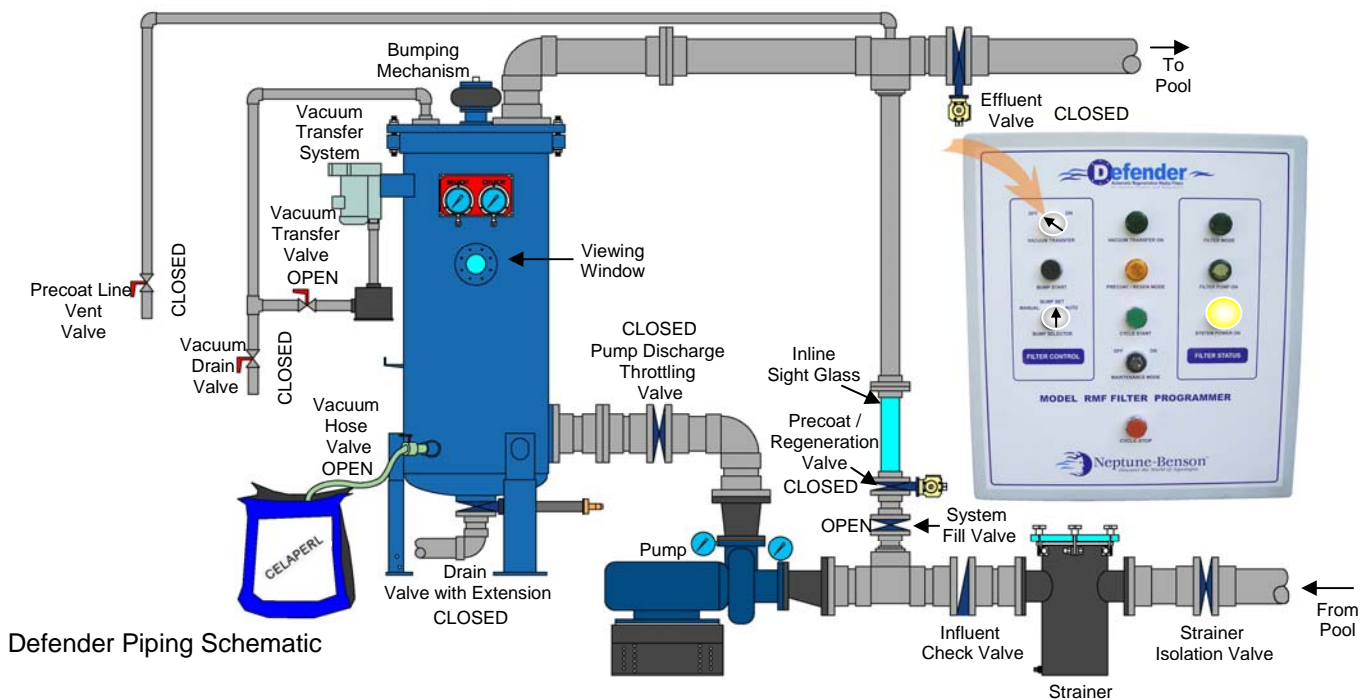

### Media Charging

8. Once you are done vacuuming in the media, turn the Vacuum Transfer Switch to Off.
9. Close Vacuum Hose Valve and Vacuum Transfer Valve.

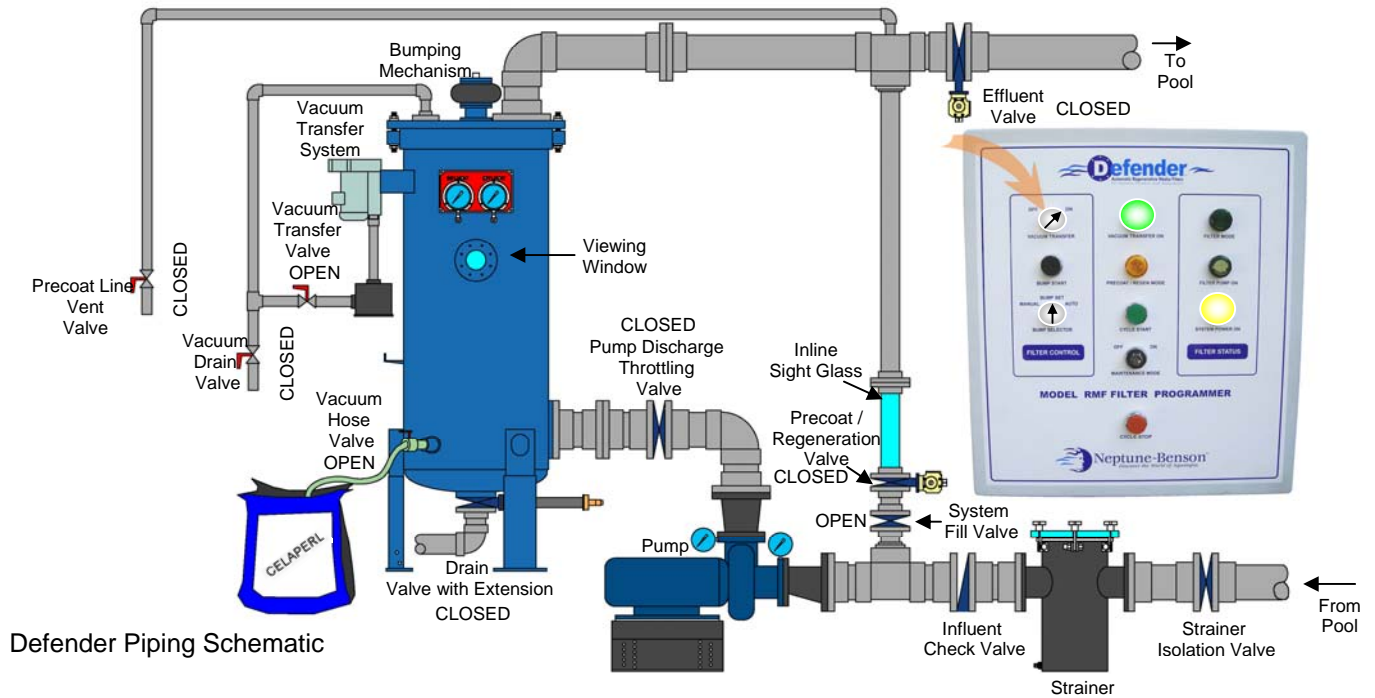

Defender Piping Schematic

### Filling the System

1. Open the Precoat Line Vent Valve.
2. Partially Open Vacuum Drain Valve.
3. Open Pump Discharge Throttling Valve.
4. Turn Bump Selector switch to Manual.

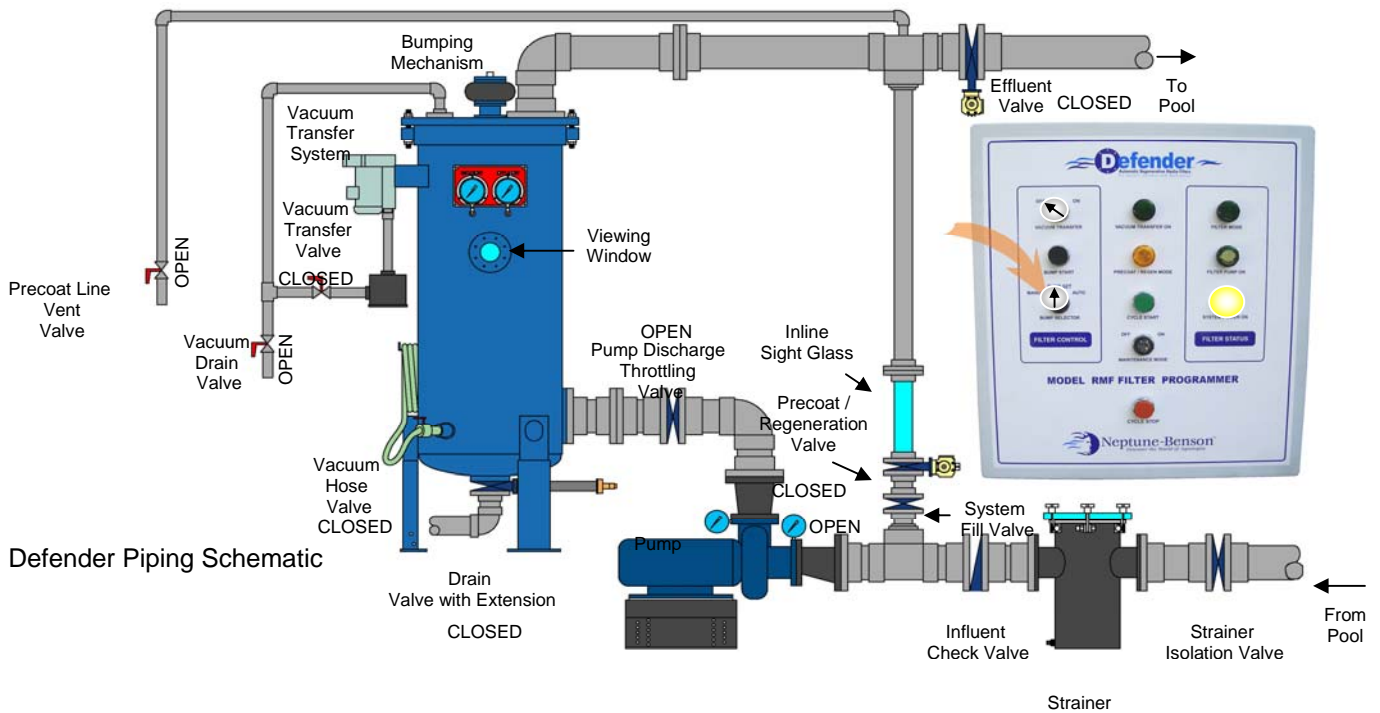

Defender Piping Schematic



Filling the System



5. Press Cycle Start to fill system.
6. If your pump motor does not have a variable frequency drive (VFD) or a soft start motor, slowly open the pump throttling valve.

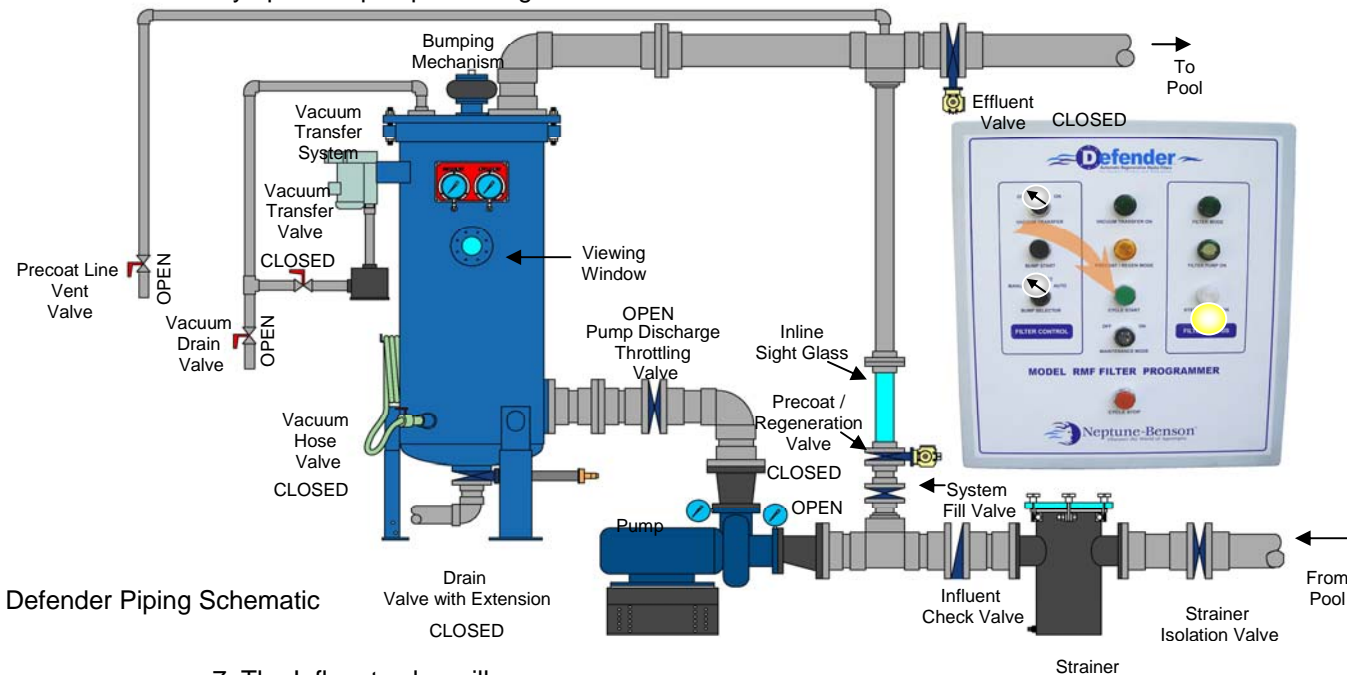

Defender Piping Schematic

7. The Influent valve will open.
8. When the water comes out of the Vacuum Drain, Close valve.
9. When the water comes out of the Precoat Line Vent Valve, Close valve.
10. The tank & piping should be full of water and all air vented out.

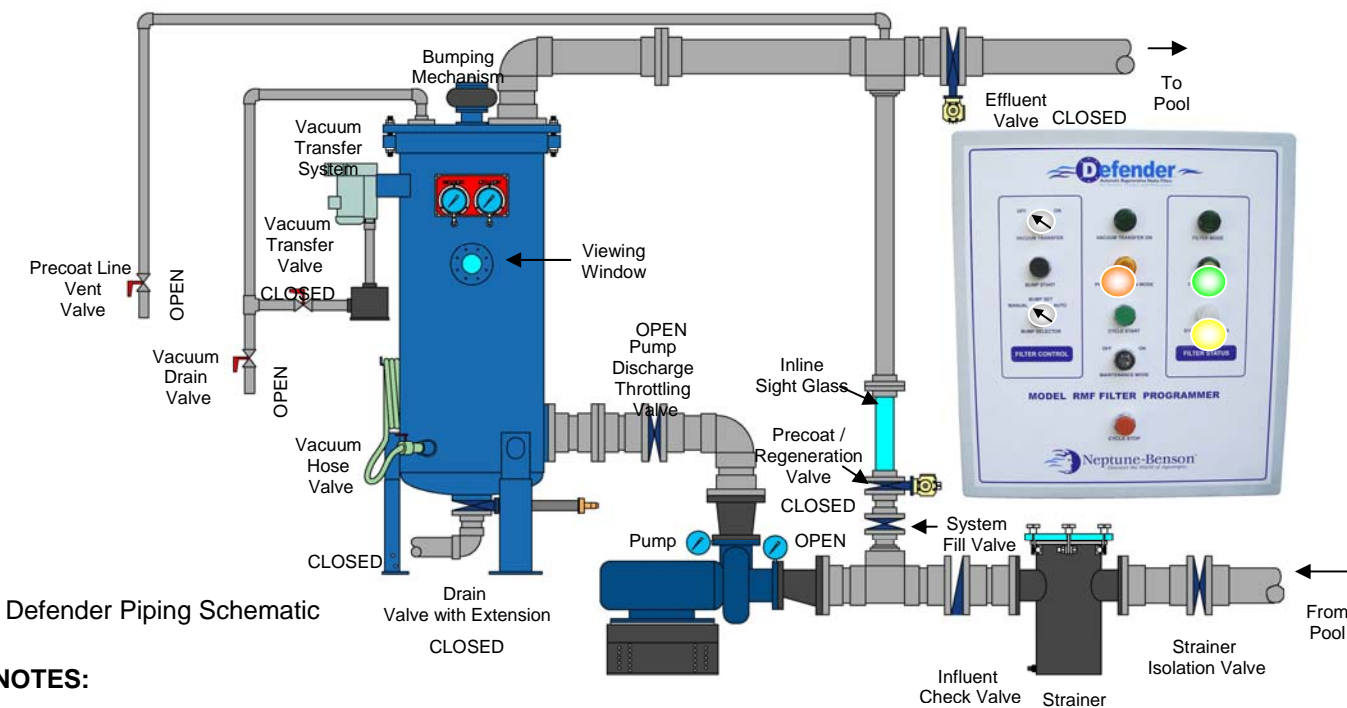

Defender Piping Schematic

NOTES:

1. If you're Defender™ Filter is below pool water level, you can fill the system by gravity before pressing Cycle Stop.
2. If the Precoat Valve opens before your system is fully filled and vented, use System Fill Valve for this procedure:
  - A. Close System Fill Valve.
  - B. When system is filled and vented, slowly open System Fill Valve.



**Precoat Mode**

1. After 60 seconds the Precoat Valve will Open and the filter will precoat for a set time of 10 minutes.
2. The filter will automatically go into Filter Mode after 10 minutes.

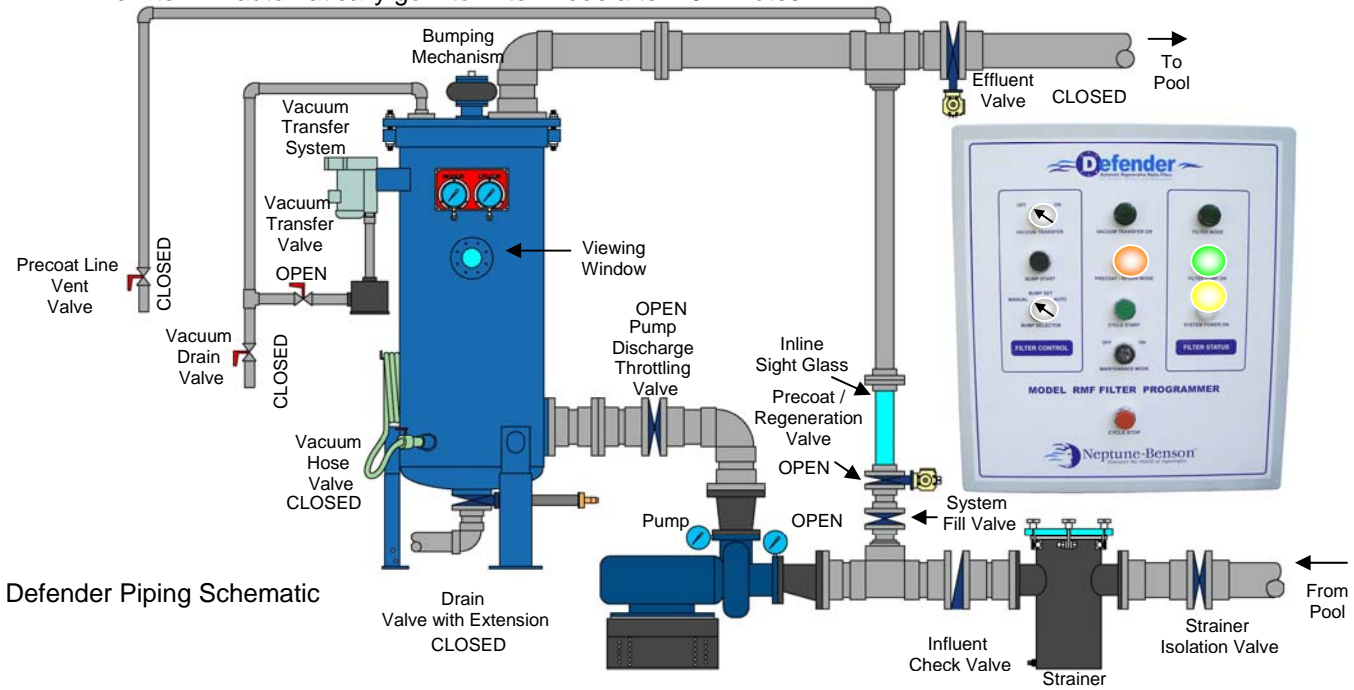

Defender Piping Schematic

**Filter Mode**

1. The Precoat Valve will Close and the Effluent Valve will Open.

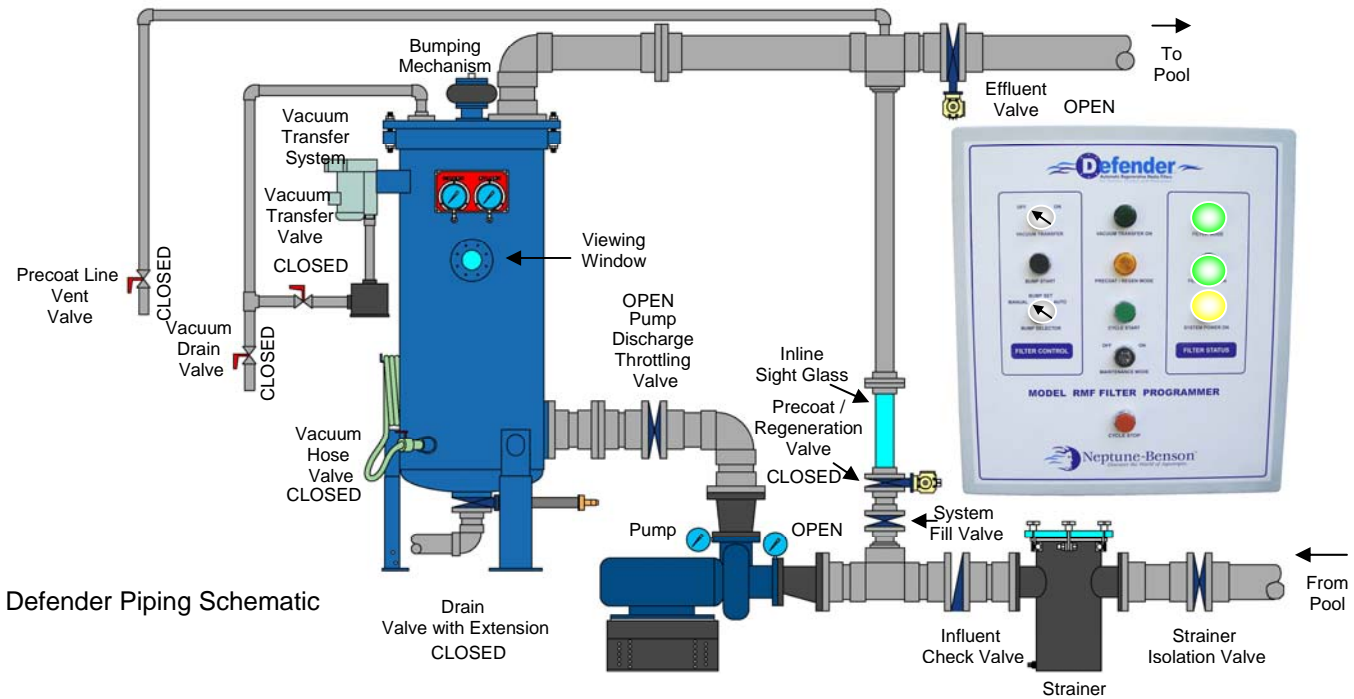

Defender Piping Schematic

**Regeneration Mode (Bumping)**

1. The filter should be Bumped daily.
2. If in Manual Mode, press Bump Start.  
If in Auto Mode, filter will perform bumping automatically.

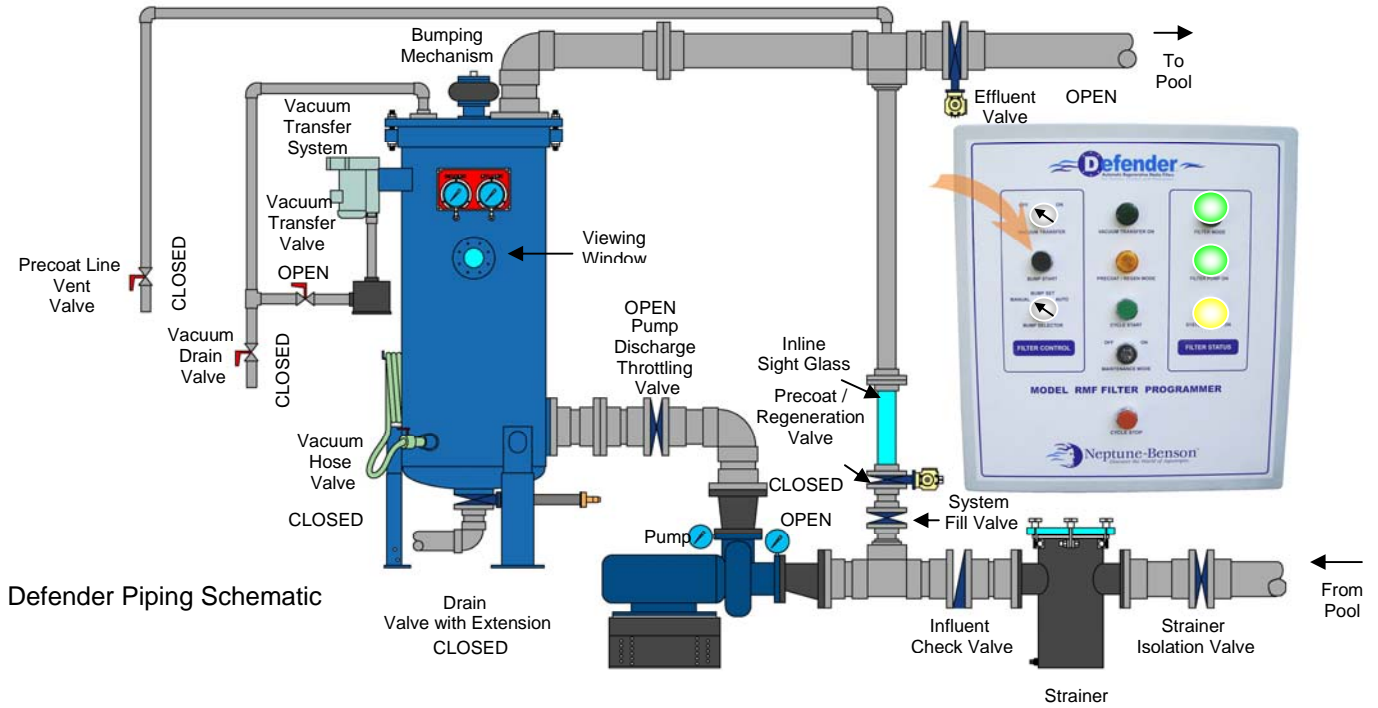

Defender Piping Schematic

3. When Bump Start is pressed the recirculating pump will stop. The Effluent Valve and Inlet Valve will Close and the filter will bump 10 times.
4. After Bumping, the filter automatically will go into Precoat Mode.

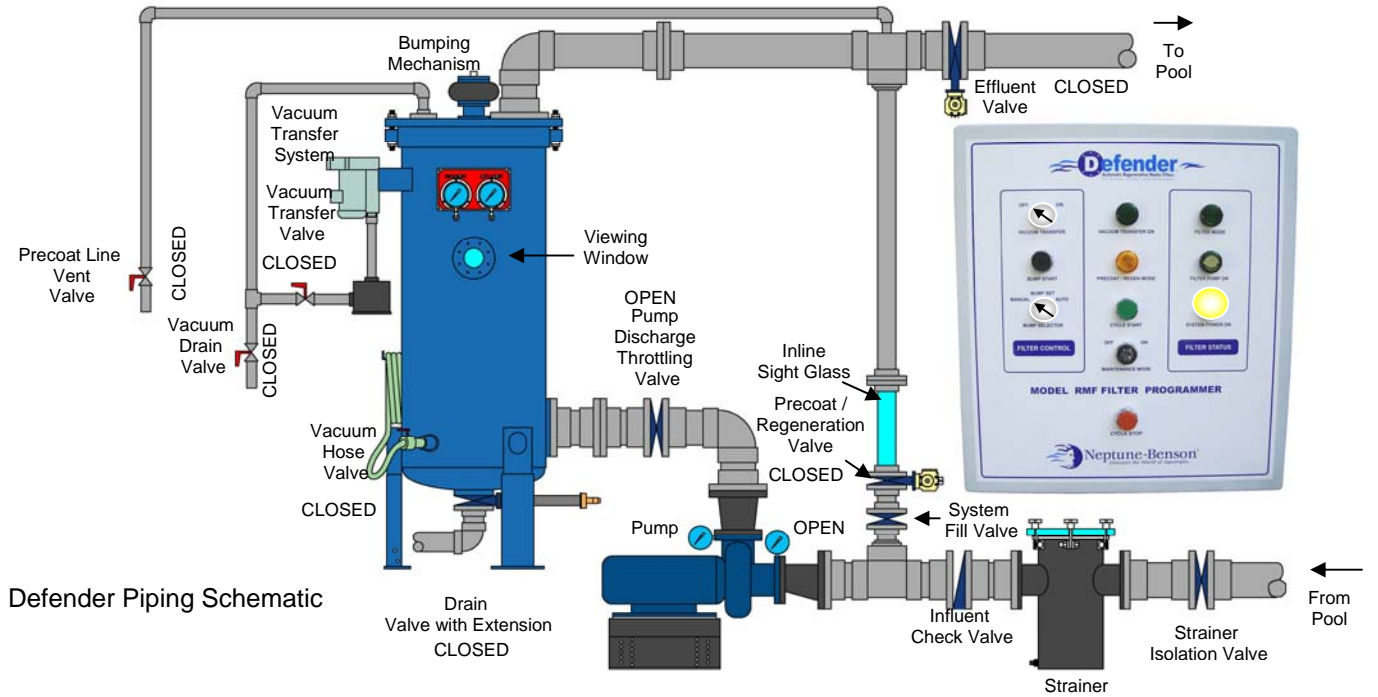

Defender Piping Schematic

5. After Precoat Mode, the filter will go into Filter Mode and the Precoat Valve will close.
6. The Effluent Valve will Open.

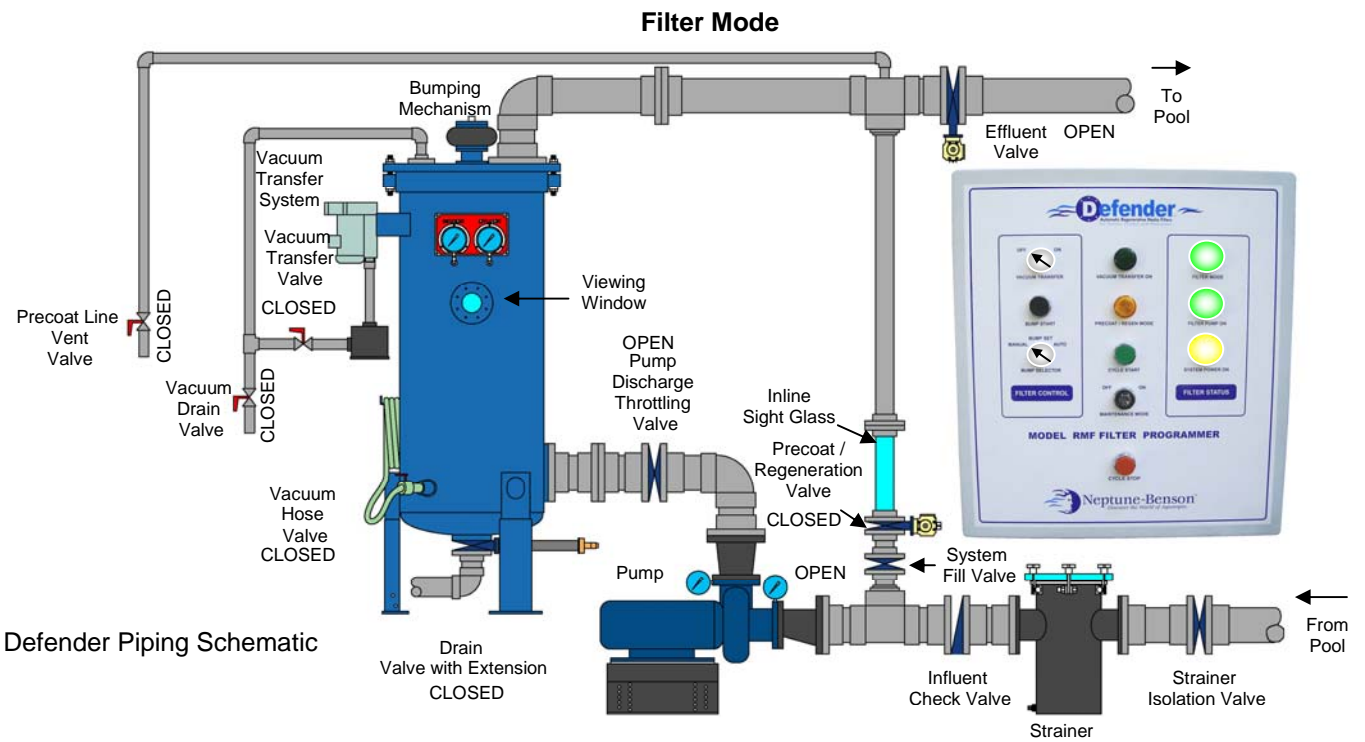
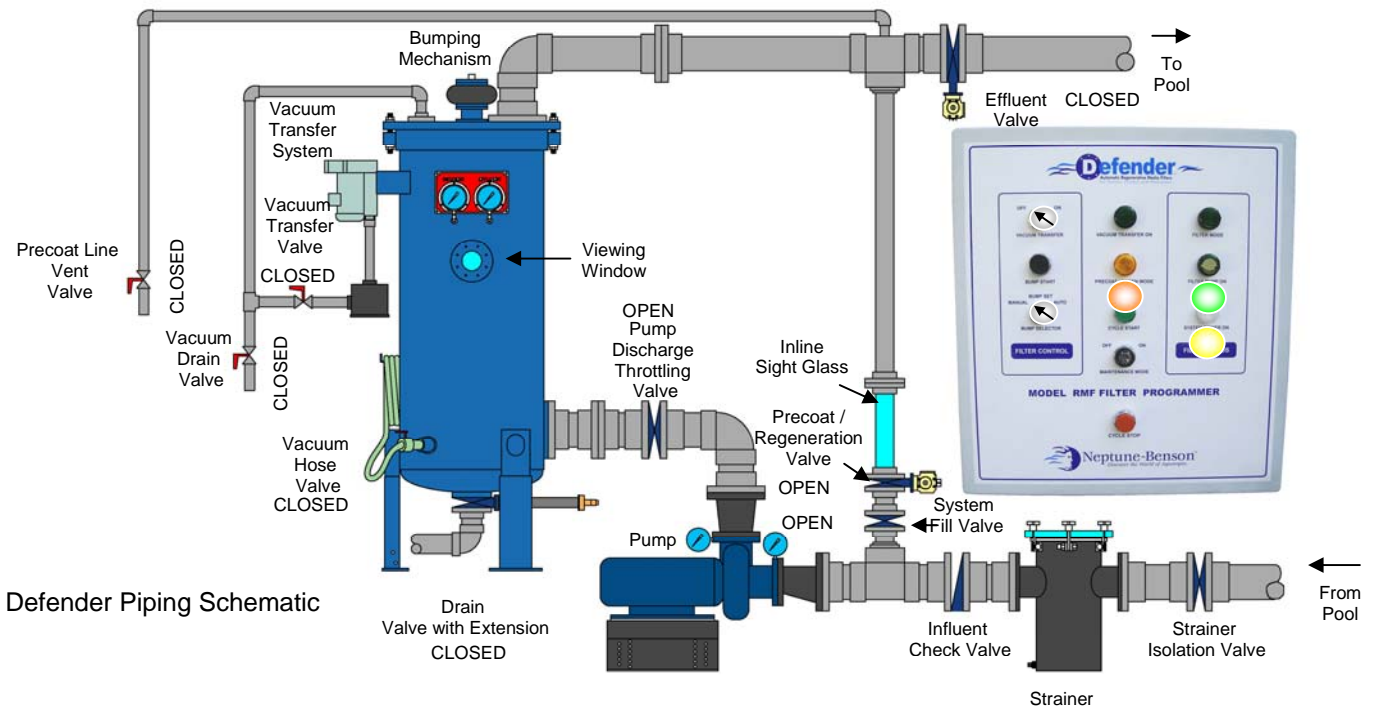

### Discharging Media

1. At some point, the media will need to be Discharged and Charged with new media.
2. While the system is in Filter Mode, Open the Drain Valve partially to clear any clogs then Close it slowly.
3. To Discharge Media, press Cycle Stop.

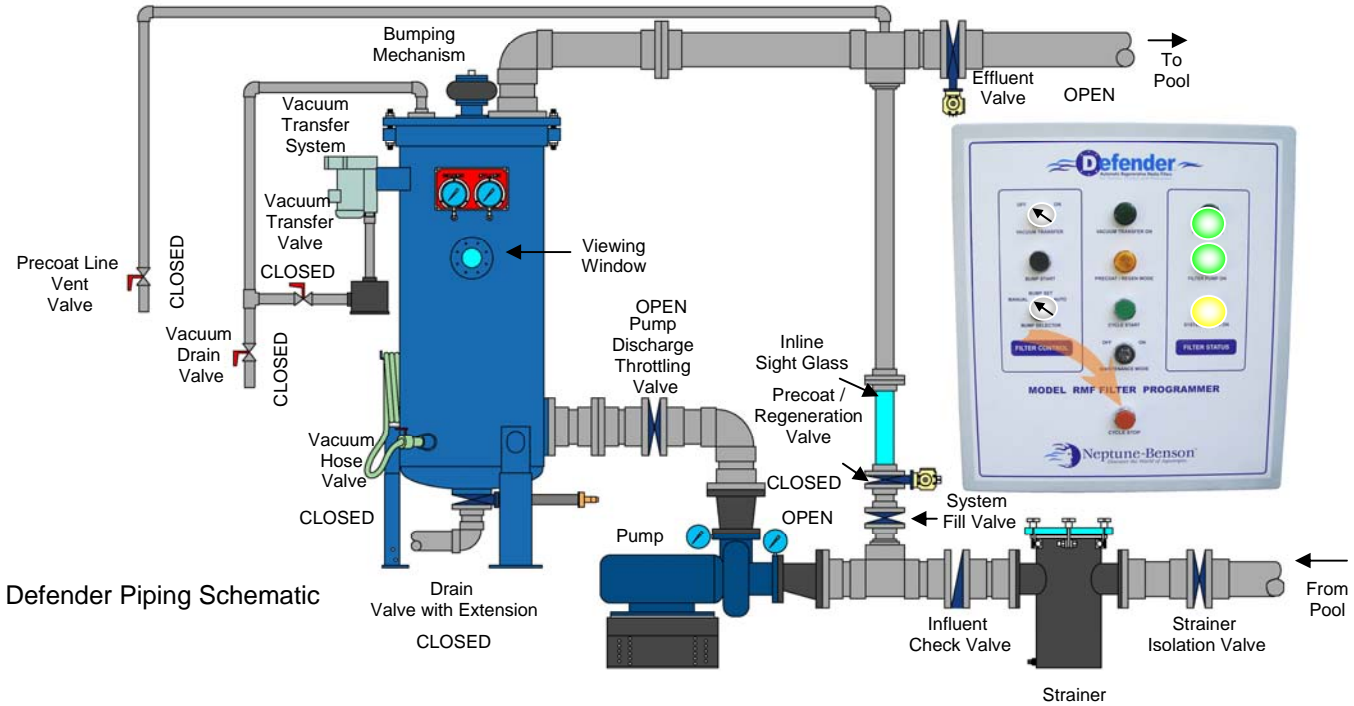

4. Turn Bump Selector switch to Bump Set.

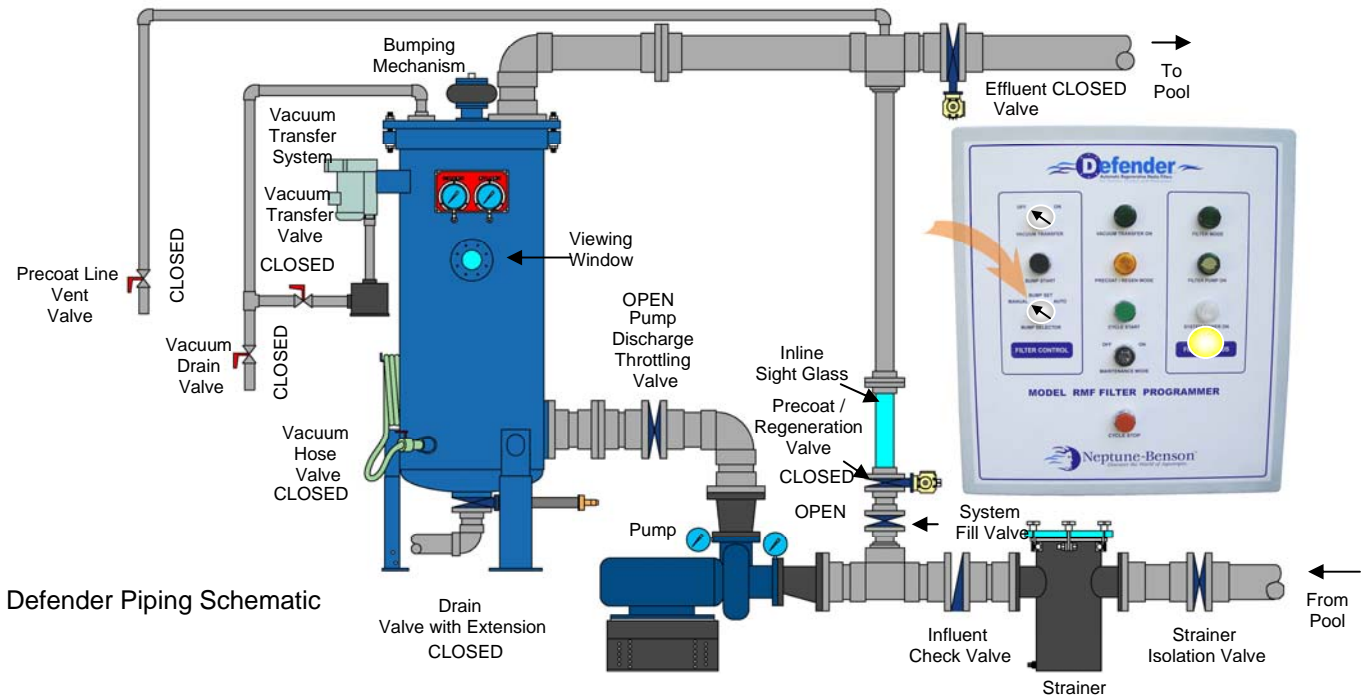



5. Bump the filter approximately (5-10) times by clicking Bump Start.

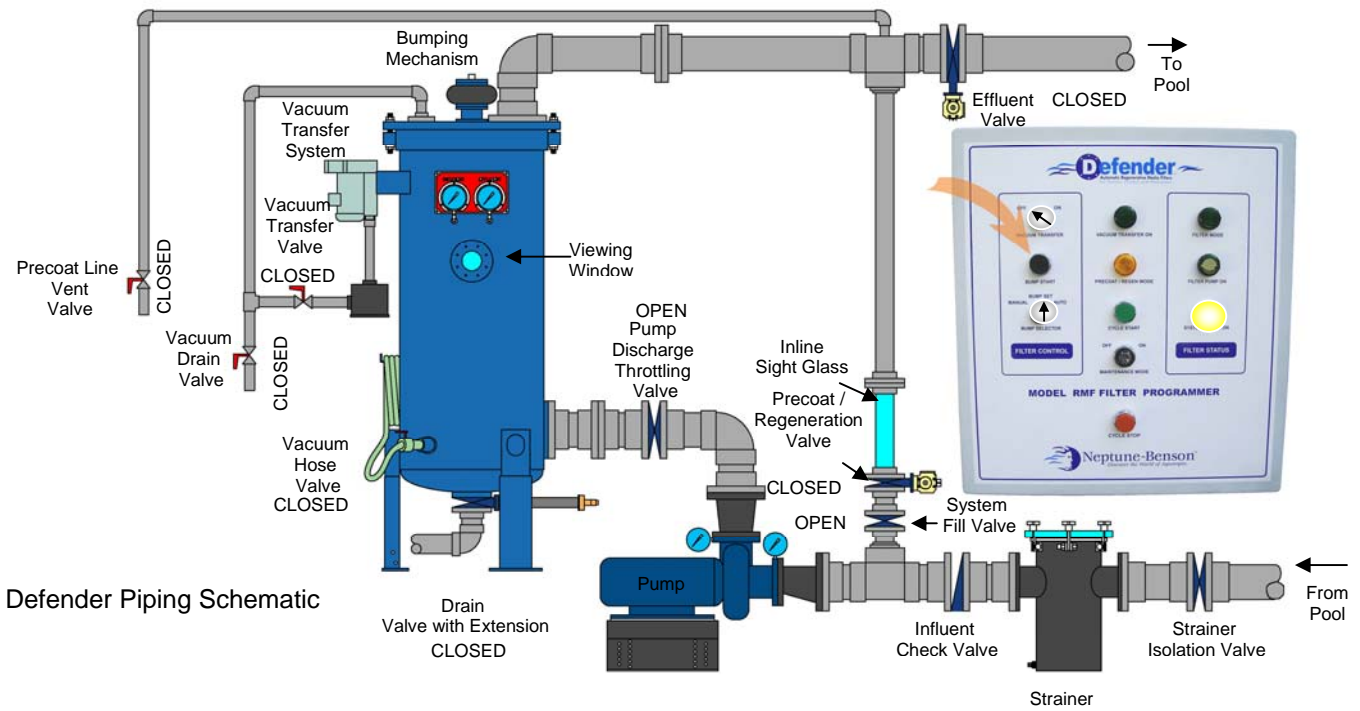

Defender Piping Schematic

6. Open Drain Valve.

7. Open Vacuum Drain Valve.

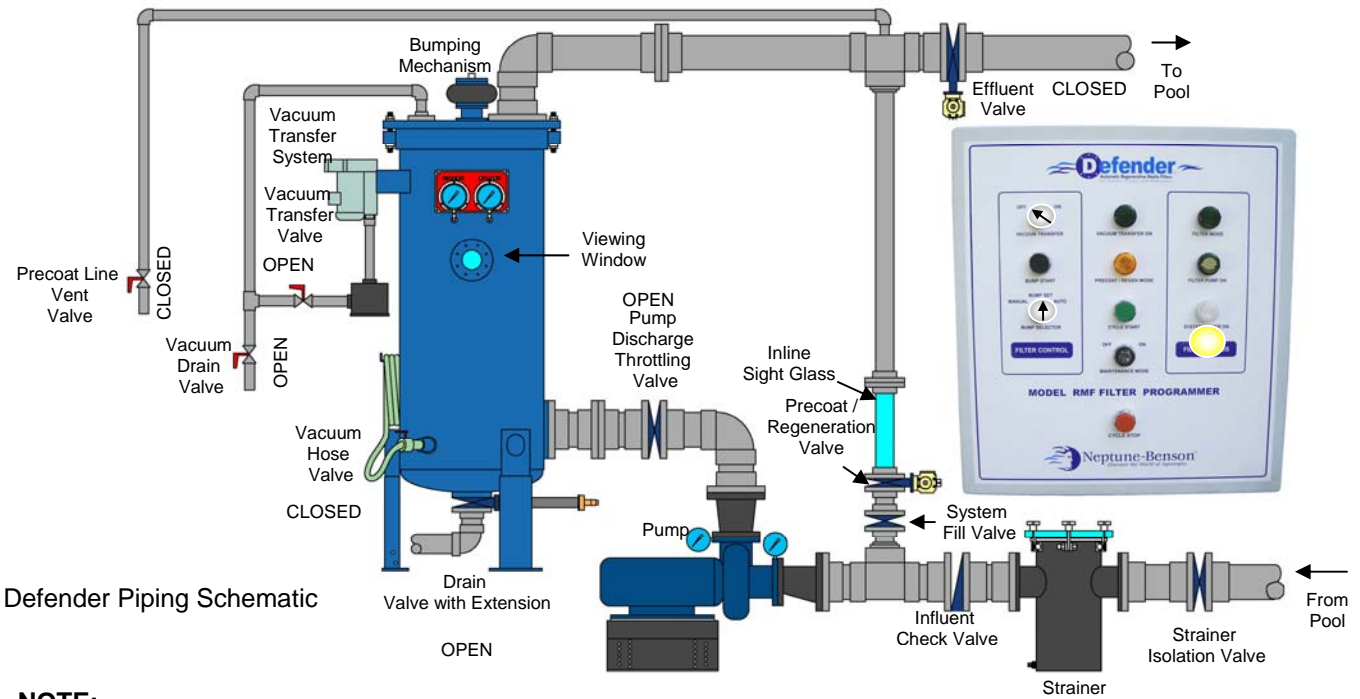

Defender Piping Schematic

**NOTE:**

If you're Defender™ Filter is below pool water level, close Pump Discharge Throttling Valve prior to opening Drain Valve.

**Discharging Media  
“Flexible Tube Rinse”**



1. Once the tank is drained, Close the Drain Valve.

**IMPORTANT!**

Before pressing Cycle Start for rinse, turn Vacuum Transfer switch on for 1-2 seconds, then Off. This will default the Precoat Valve to 60 seconds opening delay, preventing the water from draining out of the Precoat line.

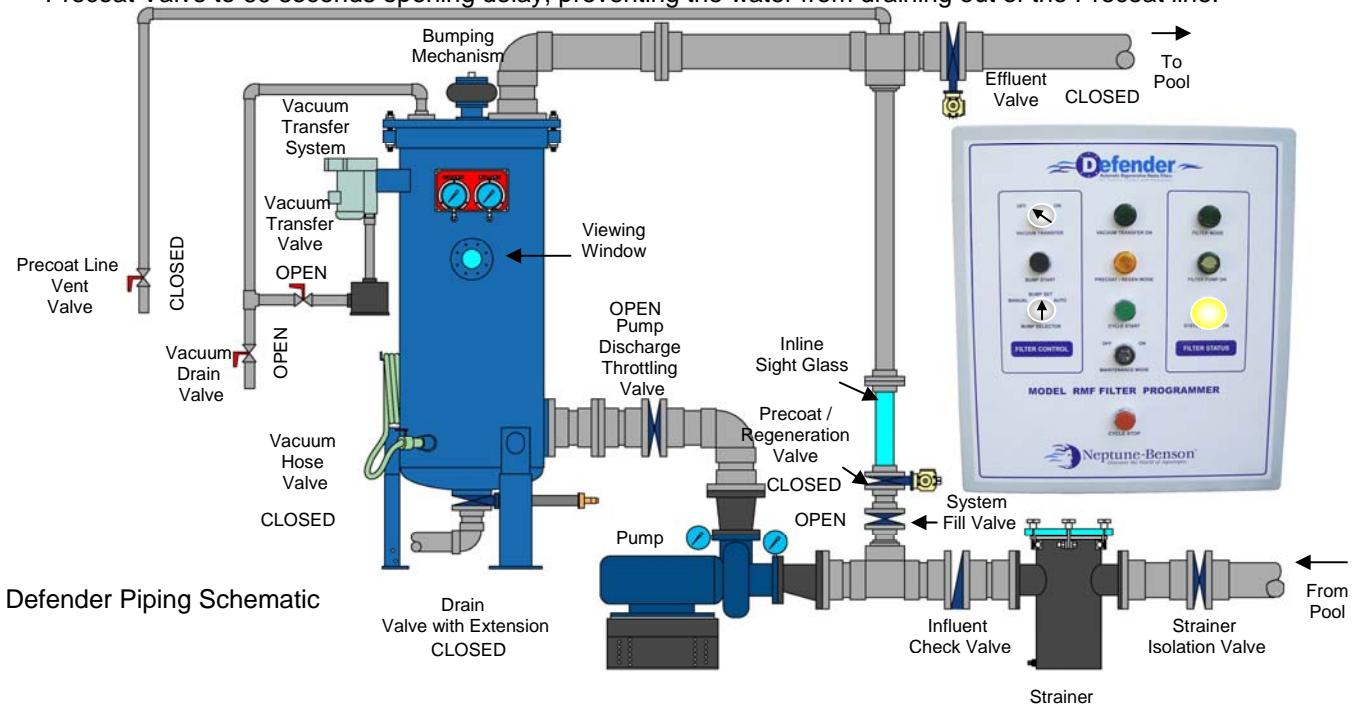

Defender Piping Schematic

2. Turn Bump Selector switch to Manual.
3. Refill the tank by pressing Cycle Start.

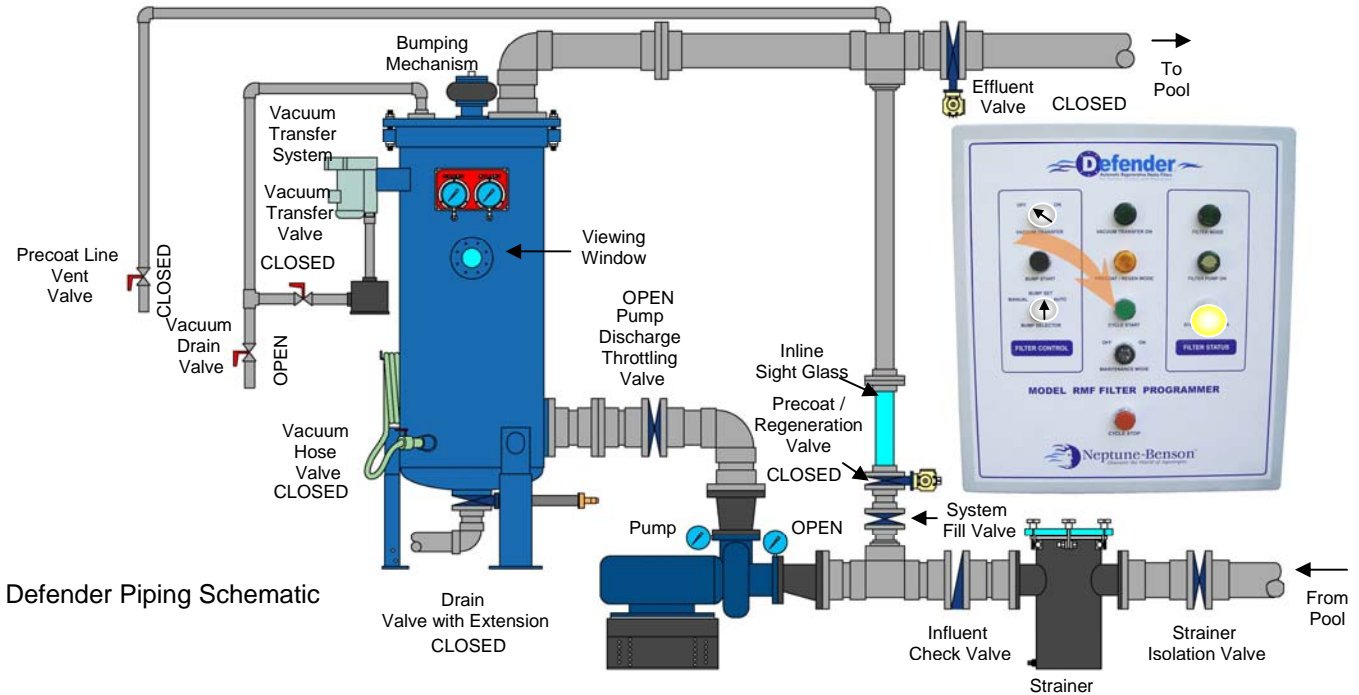

Defender Piping Schematic

**NOTE:**

If you're Pump Discharge Throttling Valve was closed, open before pressing Cycle Start.

4. When filling the system, watch as the water passes above the viewing window. Once it passes by, wait a few seconds then go into the next step.
5. Once the tank is filled, press Cycle Stop or close Pump Discharge Throttling Valve if you are filling by gravity.

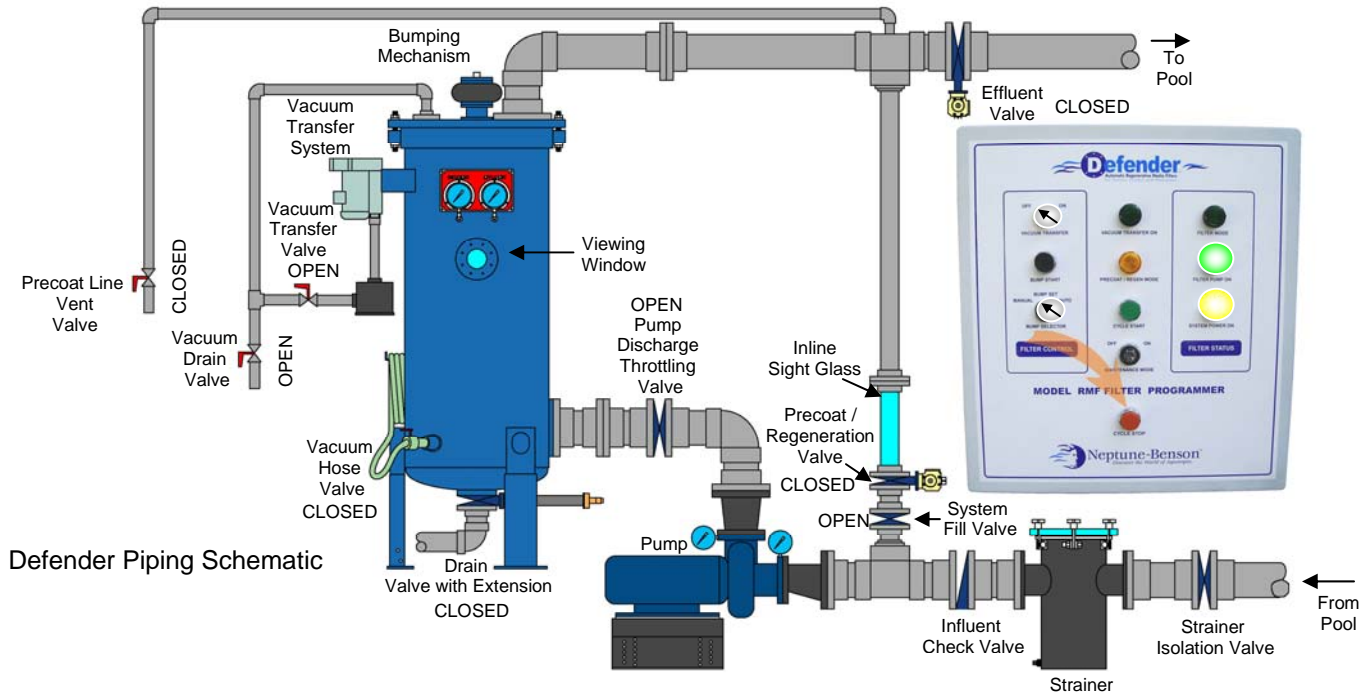

Defender Piping Schematic

6. Turn Bump Selector Switch to Bump Set.

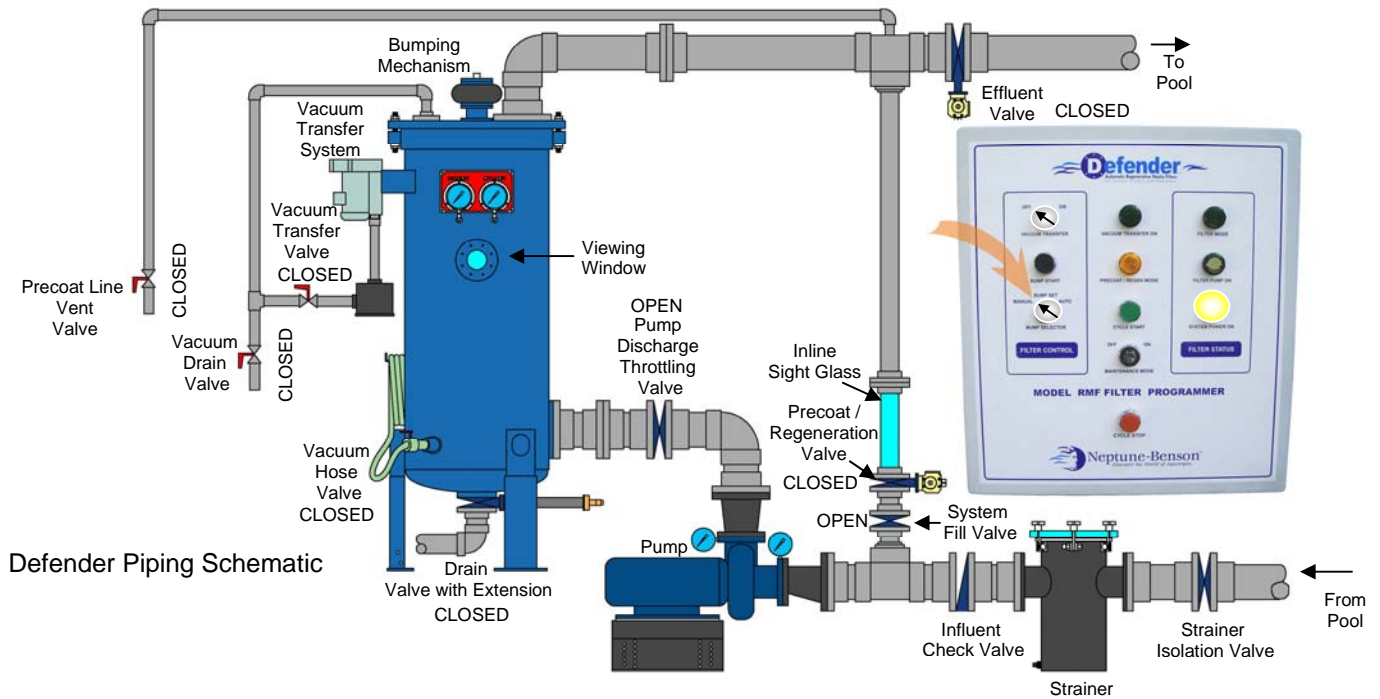

Defender Piping Schematic



7. Press Bump Start button 5-10 times.
8. Open Drain Valve and completely drain tank.

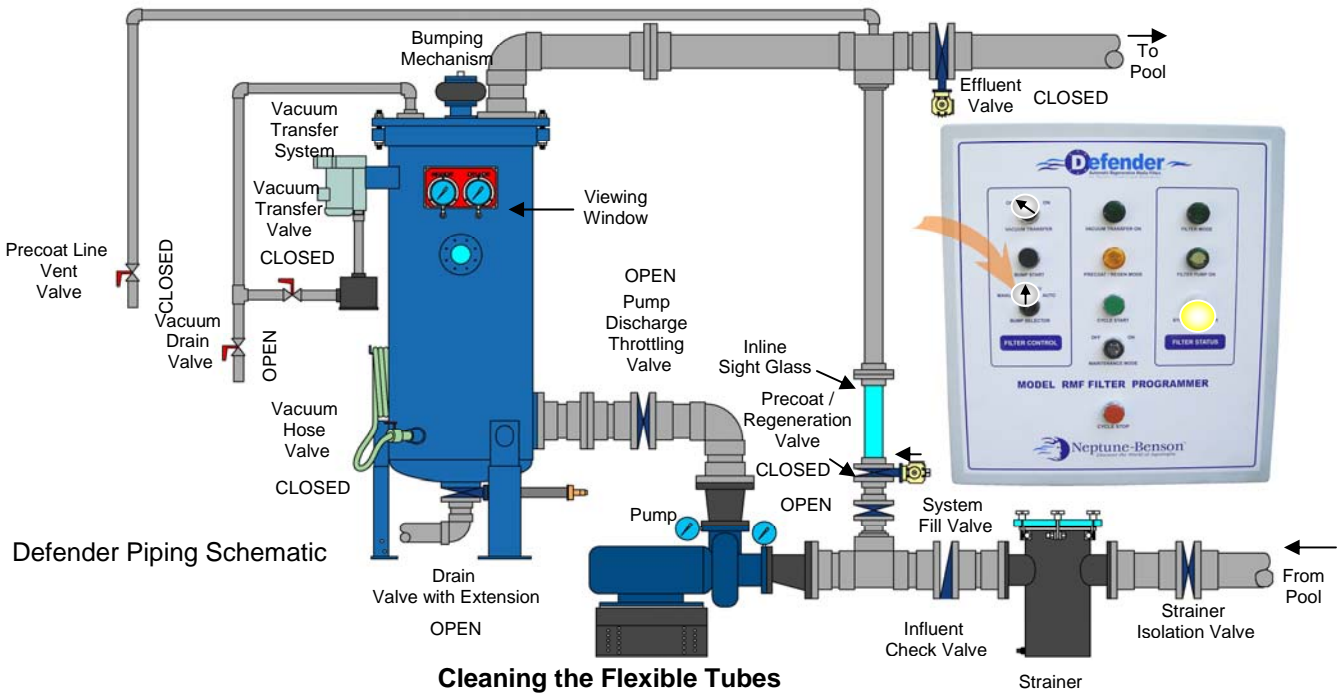

*Note: Cleaning is recommended once a year. Follow the Discharging Media instruction prior to below.*

1. Get appropriate amount of cleaner for transfer.
2. Open Vacuum Transfer Valve.
3. Open Vacuum Hose Valve.
4. Close Vacuum Drain Valve.
5. Turn the Vacuum Transfer switch to On.

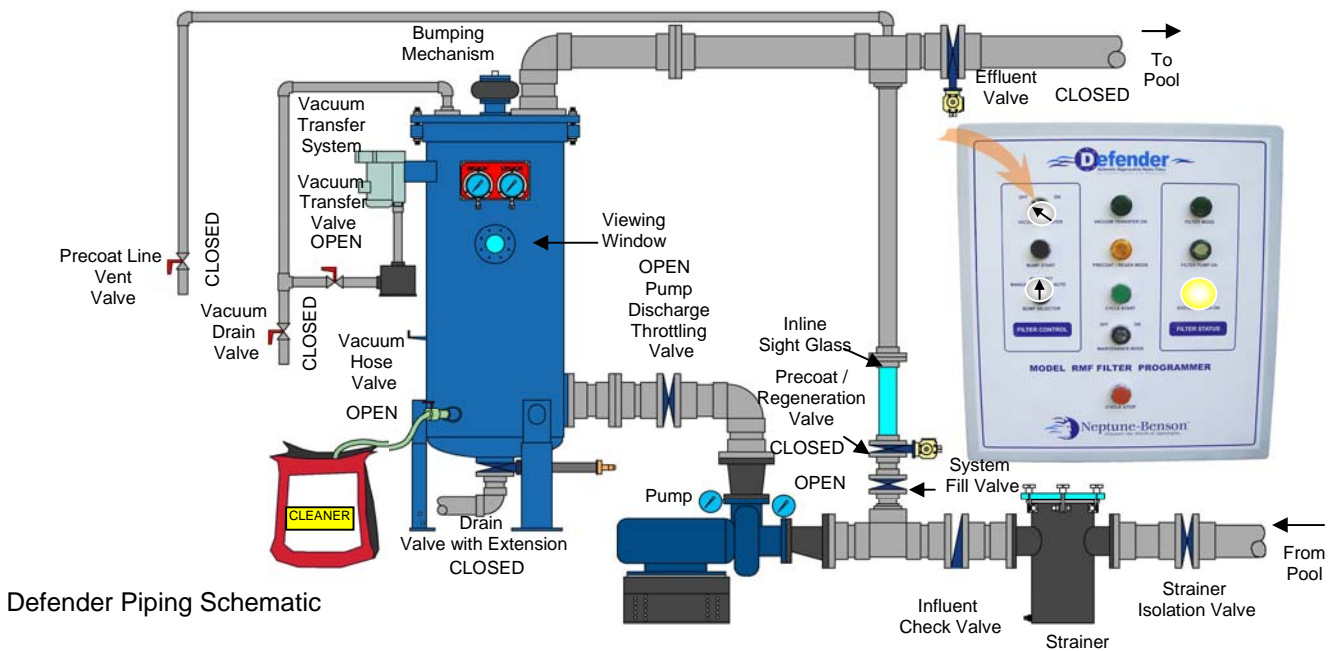

6. Once you are done vacuuming in the cleaner, turn the Vacuum Transfer Switch to Off.
7. Close Vacuum Hose Valve and Vacuum Transfer Valve.

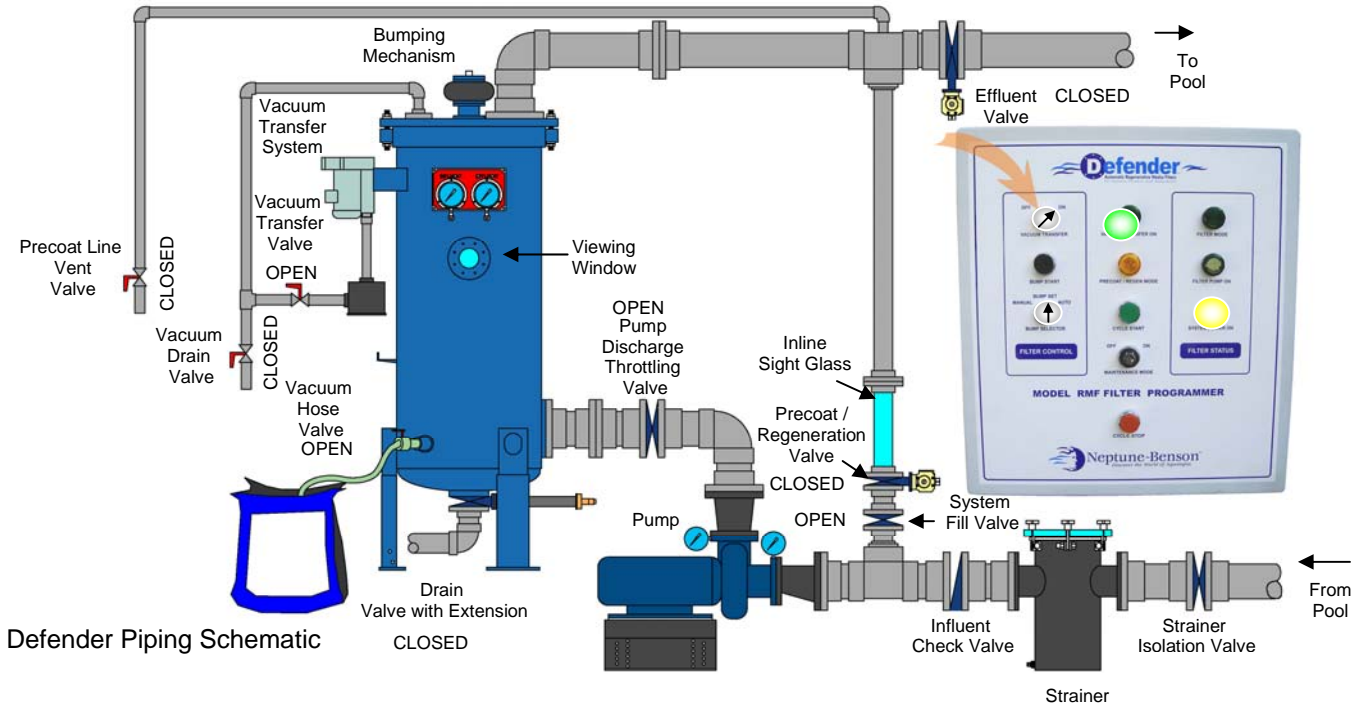

8. Turn Bump Selector switch to Manual.

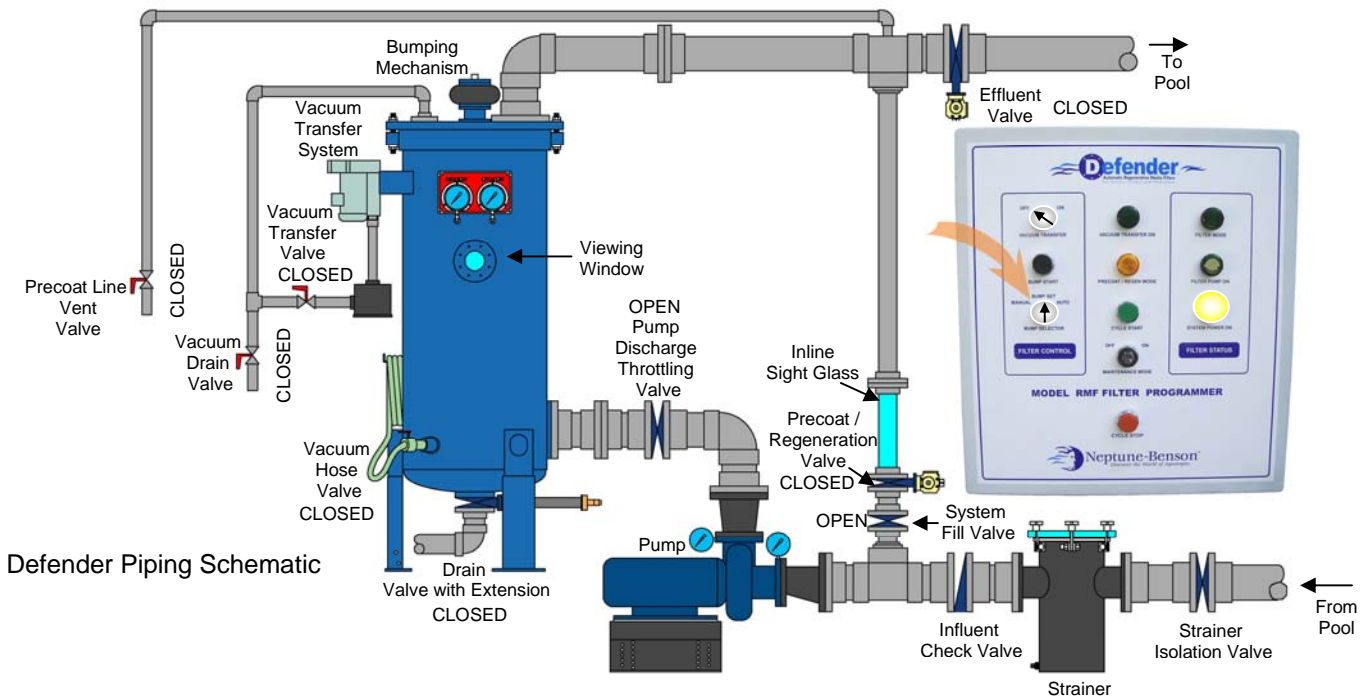

9. Open Vacuum Drain Valve.
10. Press Cycle Start to fill system.
11. If your pump motor does not have a variable frequency drive (VFD) or a soft start motor, slowly open the pump throttling valve partially.

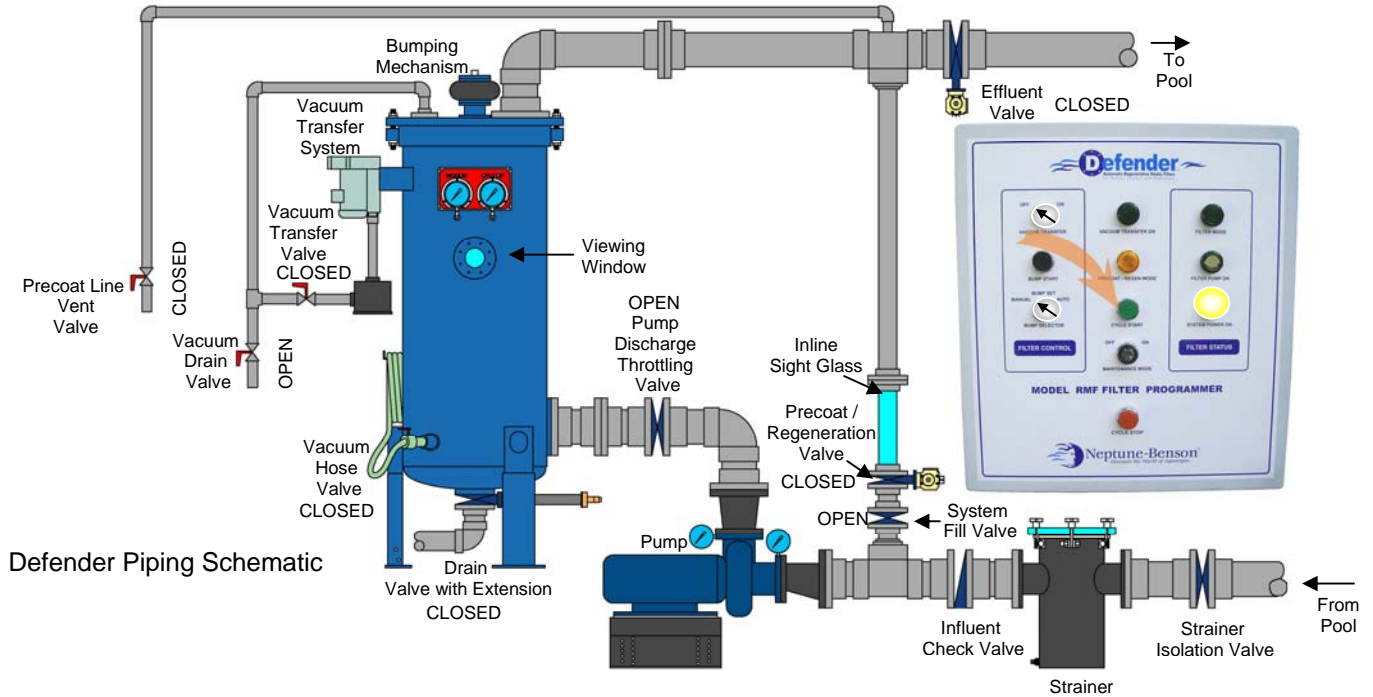

12. When filling the system, watch as water passes above the viewing window. Once it passes by, wait a few seconds then go onto the next step.
13. Once the tank is filled, press Cycle Stop.

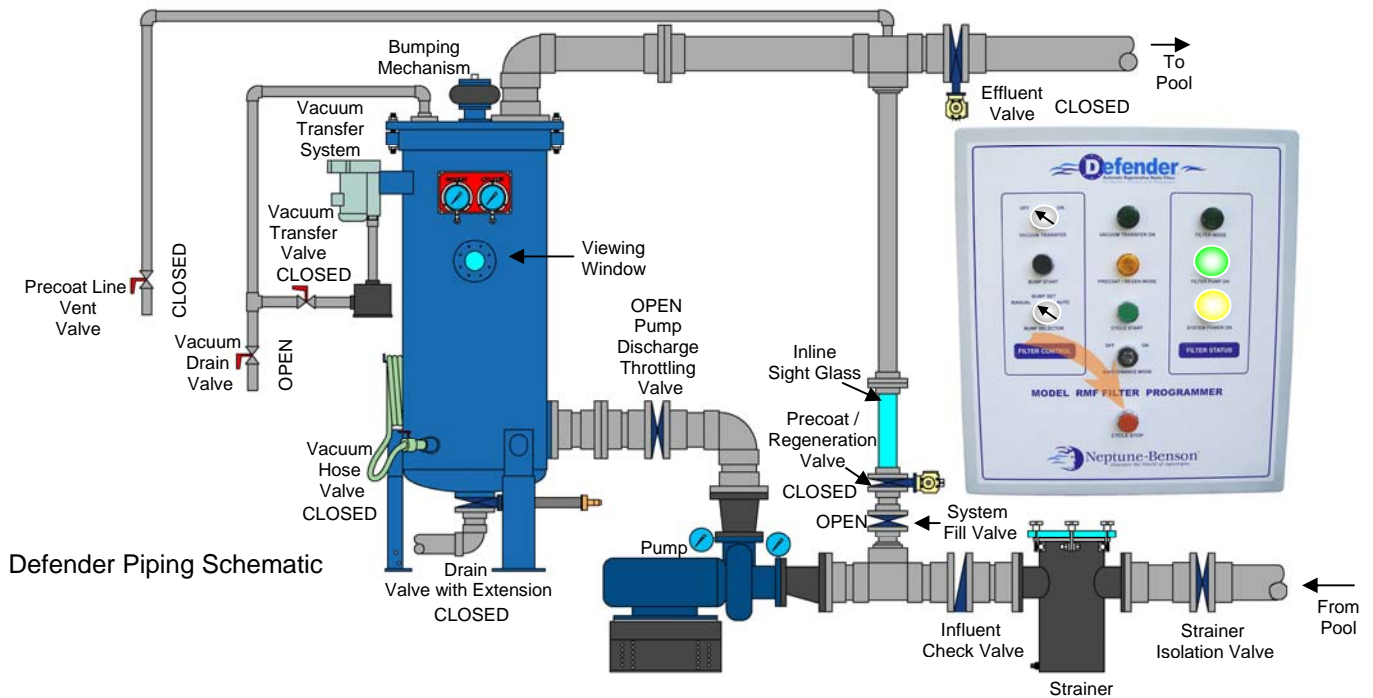

14. Close Vacuum Drain Valve.
15. Insert Key into Maintenance Mode switch & turn to On position.

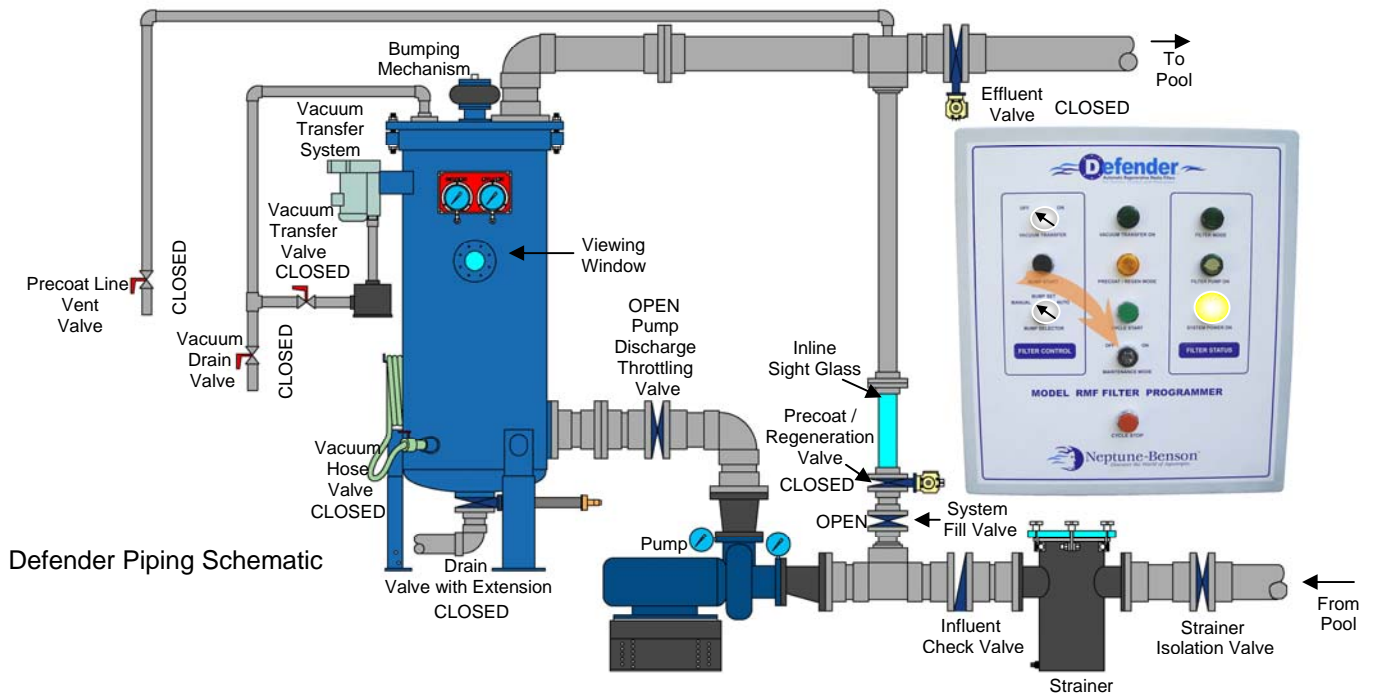

Defender Piping Schematic

16. The filter will automatically bump 6 times every 15 minutes.
17. Soak for at least 12 hours, 24 – 36 hours recommended.
18. Once done soaking, drain tank twice, by following the rinse and drain process previously shown.

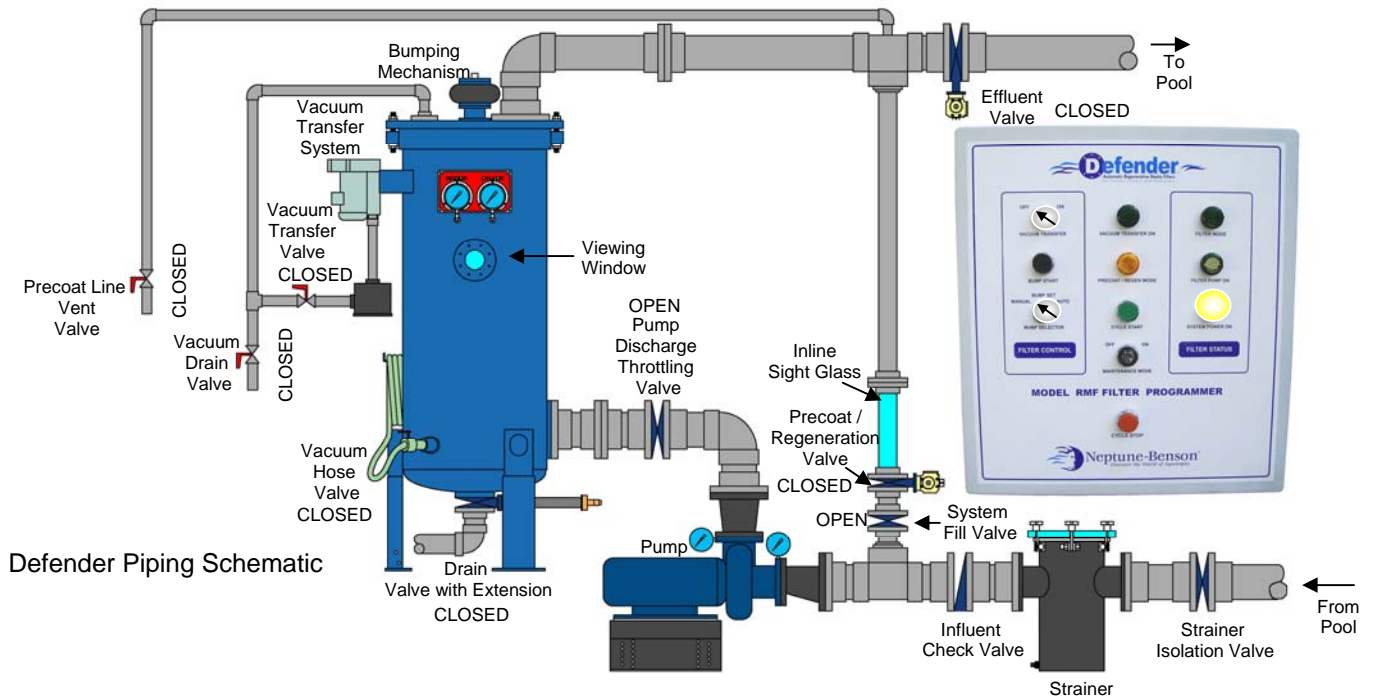

Defender Piping Schematic



## VEDLIGEHOLDELSE

### GENEREL

Defender Filtre er næsten vedligeholdelsesfrie. Som med enhver ståltank laves der en visuel inspektion. Undersøg alle slanger og forbindelser for eventuelle tegn på slid. Udskift eventuelle slidte slanger.

- Tjek boltene hver tredje måned og efterspænd hvis det er nødvendigt.
- Blæser indløbs filter efterse patron efter hvert medie skift, og rengør hvis det er nødvendigt.
- Blæser, se blæser manual for detaljer.
- Filter / Regulator – Se Filter / Regulator manual for detaljer.
  - Ved udskiftning af airline filter elementer, brug SMC Corporation del # AF40P-060S.

Rengøring af fleksible rør – de fleksible rør inde i filtret skal rengøres lejlighedsvis baseret på badebelastningen. Jo mere olie og forurenende stoffer der indføres i filtret, jo oftere vil det være nødvendigt at rengøre det. Det er påkrævet at rense rørene når indløbstrykket igen stiger i løbet af en time efter det nye medie er påfyldt. Refererer til side 44 for "Flexible tube rinse" instruktioner.

### INDENDØRS BASSIN:

- Vandlande og øvrige offentlige svømmeanlæg – To gange om året.
- Konkurrence bassin/varmtvands bassin/ spring bassin, spa etc... - En gang om året.

### UDENDØRS BASSIN:

- Op til 4 måneders drift – Ved udgangen af sæsonen.
- Op til 9 måneders drift – I midten og slutningen af sæsonen.
- Drift året rundt – 3 gange med passende mellemrum.

### MELLEM KEMISK RENGØRING:

For at få det optimale ud af dit Defender Filter mellem kemisk rengøring følg denne procedure:

1. Dræn og rens efter instruktion.
2. Luk for lufttilførslen, bump knappen sættes til bump set position.
3. Press bump knappen indtil alt luft er opbrugt.
4. Åben skueglasset.
5. Brug en højtryksrenser på bred spredning eller en haveslange med stråledyse, rens så forsigtigt slangerne gennem glasset.
6. Det er vigtigt at tage fat i alle slanger og dreje dem for at sikre total afvaskning. Dette kan gøres igennem skueglasset. Fortsæt indtil alle rør er rensat.
7. Geninstaller skueglasset, tænd for luft tilførelsen og følg instruktioner for vakuum fyldning af medie.

### NÅR TOPPEN SKAL FJERNES

Mange Defender Filtre er monteret med et hæve system på toppen af filtret. Denne er monteret på toppen af tanken og skal pga. den sjældne brug smøres med fedt inden.

### TOPPAKNING

Toppakningen skal udskiftes efter hvert løft af topdæksel. Dette er for at sikre at pakningen slutter tæt.

### FEM ÅRS VEDLIGEHOLDELSE

Efter at filtret har kørt i 5 år, skal bump komponenterne kontrolleres for at sikre at de fungerer korrekt. ( se side 50)

- Kontroller (1) Bump Mechanism Tire
- Kontroller (2) Bearing Block O-rings
- Kontroller (3) Lift Shaft O-rings
- Kontroller (1) Bearing Block Snap Ring
- Tjek Bearing Block for slør og udskift hvis det er nødvendigt.

## TI ÅRS VEDLIGEHOLDELSE

Efter 10 års drift, skal rør elementerne kontrolleres for at sikre korrekt udførelse. På det tidspunkt vil det igen være tid for det 5 årig vedligeholdelses tjek.

Kontakt AQUA-TEKNIK A/S for instruktioner og værktøj som kræves for 5-10 års vedligeholdelse.

### **Bemærk!**

**Rengør de fleksible rør mindst en gang om året som det kræves.**

## RENGØRING AF FLEKSIBLE RØR

Brug affedningsmiddel på same måde som "Filter renser" (Som oplyst på side 48)

Forslag til mængde af kemikalie per tank størrelse, se model herunder.

Defender Model #	Vol (Gal.)	Forslag (lbs.) af rens
SP-24-42-327	128	26
SP-27-48-487	159	32
SP-33-48-732	250	50
SP-41-48-1038	441	88
SP-49-48-1548	615	123
SP-55-48-2076	841	168
SP-24-30-327	102	20
SP-24-38-327	102	20
SP-30-30-595	161	32
SP-30-38-595	161	32
SP-30-42-595	198	40
SP-36-30-756	236	47
SP-36-38-756	236	47
SP-36-42-756	289	58
SP-42-30-1080	326	65
SP-42-38-1080	326	65
SP-42-42-1080	398	80
SP-48-30-1452	433	87
SP-48-38-1452	433	87
SP-48-42-1452	527	105
SP-54-30-1996	556	111
SP-54-38-1996	556	111
SP-54-42-1996	675	135
SP-60-30-2460	697	139
SP-60-38-2460	697	139
SP-60-42-2460	844	169

1. Vakuüm den foreslået mængde af kemikalie ind I tanken.
2. Fyld tanken med vand til toppen.
3. Kør pre-coat mode i 1 minut.
4. Drej nøglen til "vedligeholdelses mode" eller "element rensnings Mode".
5. Defender Filtret vil automatisk bumpe (6) gange hvert 15. minut.
6. Sæt i blød i mindst 12 timer, anbefalet 24-36 timer.
7. Dræn og fyld tanken mindst 2 gange for at fjerne al kemikalie.
8. Gå til "Påfyldning af medie i systemet – vakuüm overførsel" instruktioner.



**BUMP ASSEMBLY**

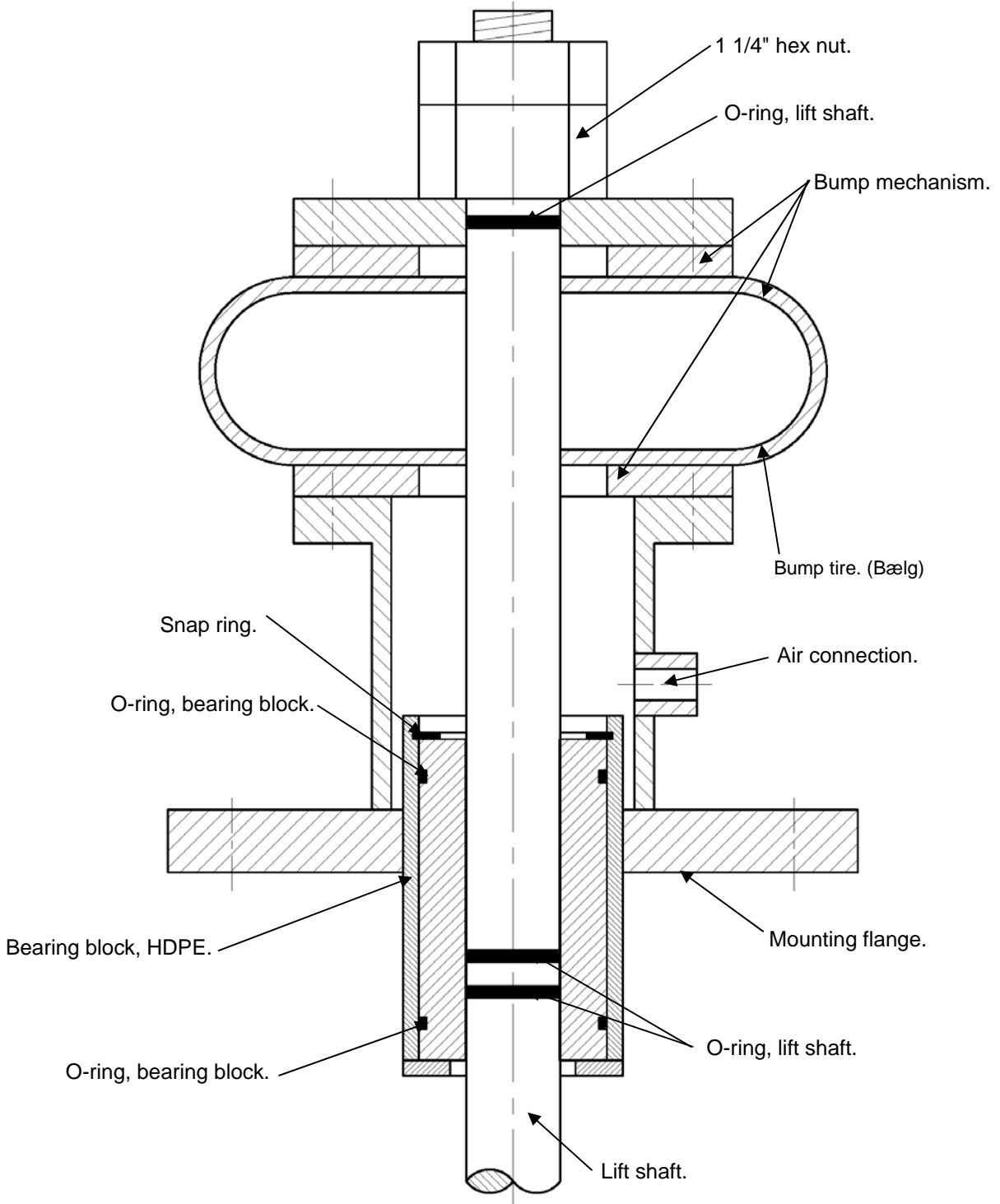

UR  
**Programmerings instruktioner for Defender uret**  
**Side 1 of 3**



**Instruction Manual**

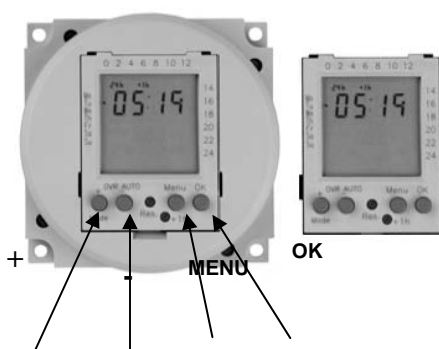

20 memories time switches

### 1. Indstilling af klokkeslæt og DAG

Tiden burde allerede være indstillet. For at justere tiden, skal du gøre følgende:

- a.) Tryk på MENU (24h skal vises, blinkende)
- b.) Tryk på OK ( tidligere vist tid skal fremkomme igen med "time" angivelsen blinkende)
- c.) Tryk på + eller - knapperne for at ændre time og derefter trykke på OK (nu skal minutterne blinke)
- d.) Tryk på + eller - knapperne for at ændre minutter, og tryk derefter på OK (nu vil en lille linje blinke til venstre ved siden af notering af dagene i ugen)
- e.) Tryk på + eller - knapperne for at ændre placeringen af den blinkende linie, så det er ved siden af den dag i ugen, som det i øjeblikket er.

## Programmerings instruktioner for Defender uret

### Side 2 of 3

#### 2. PROGRAMMERING uret til et bump

Du er nødt til at oprette et program for hvert ON og OFF tid, du ønsker. EKSEMPEL: Hvis du ønsker at BUMPET forekomme på samme tid hver dag, vil du kun behøve at skabe (2) programmer (prog 01 og prog 02). En for ON tiden og en for OFF tid.

Efter klokkeslæt og ugedag er indtastet, kommer en skærm med prog 01 med en halvcirkel med en prik inden i, under det, frem. Prikken betyder ON tiden. Du vil bemærke, at dette skærmbillede også har tidspunktet i toppen og dagene i ugen på venstre side.

**a.)** Tryk på OK-knappen, og time afsnittet vil blinke. Brug + og - knapperne for at indtaste den tid af døgnet hvor du ønsker, at BUMPET skal forekomme.

**b.)** Tryk på OK-knappen, og minut afsnittet vil blinke. Brug + og - knapperne for at indtast den tid af døgnet hvor du ønsker, at BUMPET skal forekomme.

**c.)** Tryk på OK-knappen, og nu vil alle (7) dage i ugen have en lille linje blinkende ved siden af dem. Brug + og - knapperne for at vælge den dag (e), som du ønsker dette skal forekomme

**d.)** Tryk på OK-knappen, og nu vises prog 02, der bør have en halvcirkel uden et punktum i den, lige under det. Dette er OFF TIME. (Bemærk: OFF tid kræves kun, så uret kan gå videre til ON således at næste bump kan foretages. The BUMP vil færdiggøre sin cyklus og slukke efter det er færdigt.)

**e.)** Du ønsker at programmere OFF tiden til at være 30 minutter mere end ON tiden, og det skal have de samme "dage" programmeret som ON tiden. Så følg trin a til c (ovenfor) til at programmere OFF tid.

Uret er NU programmeret til at BUMPE samme tidspunkt hver dag, 7 dage i ugen.

Hvis du vil have et program, der bumper på samme tid mandag til fredag, men du vil have et andet tidspunkt om lørdagen og søndagen, vil det være nødvendigt at skabe program PROG 01 (ON) og prog 02 (OFF) for mandag til fredag og derefter PROG 03 (ON) og prog 04 (OFF) for lørdag og Søndag. Følg trin A til E for at programmere de rette tidspunkter og dage.

## Programmerings instruktioner for Defender uret Side 3 of 3

### SPECIAL CLOCK SITUATIONER

Hvis du vil have det, så du BUMPER "manuelt" (MAN) i løbet af ugen, men ønsker at BUMPE "automatisk" (AUTO) i løbet af weekenden, så er du nødt til at oprette prog 1 (ON) og prog 2 (OFF) for lørdag og søndag med det samme on & off-tider.

#### **Konvertering fra Manuel mode (MAN) til Automatic mode (AUTO)**

BUMP systemet, som du normalt ville gøre om fredagen. Når systemet går i BUMP mode, ændre fra MAN til AUTO. Systemet vil stoppe, når BUMPET er færdigt. Tryk nu CYCLE START knappen. Systemet vil nu gå i Regenerering / PRECOAT MODE og derefter gå til FILTER MODE efter afslutningen.

#### **Konvertering fra Automatic mode (AUTO) til Manuel mode (MAN)**

Det første der gøres om morgenen er at skifte fra AUTO til MAN (systemet vil lukke ned). Vent (5) sekunder for at systemet lukker ned og tryk derefter på CYCLE START (systemet vil starte og begynde regenerering). Vent (5) sekunder og tryk derefter på BUMP knappen. Systemet vil derefter foretage en MANUAL BUMP.

## ACCESSORY COMPONENTS BLOWER MANUAL

PART NO. 70 - 6000 F2-200 (REV-J)

# STANDARD REGENAIR BLOWER

## OPERATION & MAINTENANCE MANUAL



Model R1 Shown



Model R6P350A Shown



Model R7P Shown

Thank you for purchasing this Gast product. It is manufactured to the highest standards using quality materials. Please follow all recommended maintenance, operational and safety instructions and you will receive years of trouble free service.

 <b>WARNING</b>	
	<p><b>PLEASE READ THIS MANUAL COMPLETELY BEFORE INSTALLING AND USING THIS PRODUCT. SAVE THIS MANUAL FOR FUTURE REFERENCE AND KEEP IN THE VICINITY OF THE PRODUCT.</b></p>

**General information**

This manual does not apply to:

- SDR Series blowers without motors
- Blowers powered with Explosion Proof Motors

Product Use Criteria:

- Pump only clean, dry air.
- Operate at -20°F - 104°F (-29°C - 40°C).
- Protect unit from dirt & moisture.
- Do not pump flammable or explosive gases or use in an atmosphere that contains such gases.
- Protect all surrounding items from exhaust air. This exhaust air can become very hot.
- Corrosive gases and particulate material will damage unit. Water vapor, oil-based contaminants or other liquids must be filtered out.
- The blower must be installed with the properly sized inlet and inline filters, gauges and relief valves to protect the product from dirt and over-heating.
- Consult your Gast Distributor/Representative before using at high altitudes.



ISO 9001 &amp; 14001 CERTIFIED

[www.gastmfg.com](http://www.gastmfg.com)

©Registered Trademark™ Trademark of Gast Manufacturing Inc., Copyright ©2002 Gast Manufacturing Inc. All Rights Reserved.



Select fuses, motor protective switches or thermal protective switches to provide protection. Fuses act as short circuit protection for the motor, not as protection against overload. Incoming line fuses must be able to withstand the motor's starting current. Motor starters with thermal magnetic overload or circuit breakers protect motor from overload or reduced voltage conditions. Motors without automatic restart require thermal protection or magnetic over-current cutoff to prevent motor overloading from one phase in a 3-phase circuit, high starting frequency or jammed blower.

The power required will rise as differential pressure increases. The wiring diagram attached to the product or on page 6 of this manual provides required electrical information. Large motors have two diagrams, one for 50Hz wiring specifications and the other for 60Hz wiring specifications. Check that the power source is correct to properly operate the dual-voltage motor. If additional information is required, please consult your Gast Distributor/Representative.

**Electrical Connection**

**⚠ WARNING**

**Electrical Shock Hazard**

**This product must be properly grounded.**

**Do not modify the plug provided. If it will not fit the outlet, have the proper outlet installed by a qualified electrician.**

**If repair or replacement of the cord or plug is necessary, do not connect the grounding wire to either flat blade terminal. The wire with insulation that is green or green with yellow stripes is the grounding wire.**

**Check the condition of the power supply wiring. Do not permanently connect this product to wiring that is not in good condition or is inadequate for the requirements of this product.**

**Failure to follow these instructions can result in death, fire or electrical shock.**

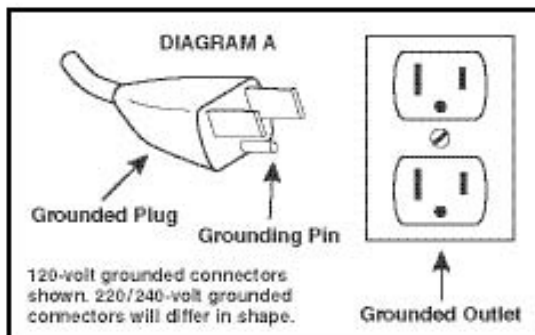

**Model with a power supply cord:**

This product must be grounded. For either 120-volt or 220/240-volt circuits connect power supply cord grounding plug to a matching grounded outlet. Do not use an adapter. (See DIAGRAM A)

In the event of an electrical short circuit, grounding reduces the risk of electric shock by providing an escape wire for the electric current. This product may be equipped with a power supply cord having a grounding wire with an appropriate grounding plug. The plug must be plugged into an outlet that is properly installed and grounded in accordance with all local codes and ordinances.

Check with a qualified electrician or serviceman if the grounding instructions are not completely understood, or if you are not sure whether the product is properly grounded. Do not modify the plug provided. If it will not fit the outlet, have the proper outlet installed by a qualified electrician.

**Model that is permanently wired:**

This product must be connected to a grounded, metallic, permanent wiring system, or an equipment grounding terminal or lead on the product.

Power supply wiring must conform to all required safety codes and be installed by a qualified person. Check that supply voltage agrees with that listed on product nameplate.

**Extension cords:**

Use only a 3-wire extension cord that has a 3-blade grounding plug. Connect extension cord plug to a matching 3-slot receptacle. Do not use an adapter. Make sure your extension cord is in good condition. Check that the gage wire of the extension cord is the correct size wire to carry the current this product will draw.

An undersized cord is a potential fire hazard, and will cause a drop in line voltage resulting in loss of power causing the product to overheat. The following table indicates the correct size cord for length required and the ampere rating listed on the product nameplate. If in doubt, use the next heavier gage cord. The smaller the gage number, the heavier the wire gage.

Minimum gage for extension cords											
Amps	Volts		Length of cord in feet								
	120 v	240 v	25	50	100	150	200	250	300	400	500
0-2	18	18	18	16	16	14	14	12	12	10	10
2-8	18	18	16	14	14	12	12	10	10	8	8
8-4	18	18	16	14	12	12	10	10	8	8	8
4-5	18	18	14	12	12	10	10	8	8	8	8
5-6	18	16	14	12	10	10	8	8	8	8	8
6-8	18	16	12	10	10	8	8	6	6	6	6
8-10	18	14	12	10	8	8	8	6	6	4	4
10-12	16	14	10	8	8	6	6	4	4	4	4
12-14	16	12	10	8	6	6	6	4	4	2	2
14-16	16	12	10	8	6	6	4	4	4	2	2
16-18	14	12	8	8	6	4	4	4	2	2	2
18-20	14	12	8	6	6	4	4	2	2	2	2



## OPERATION

 **WARNING**
**Injury Hazard**

**Install proper safety guards as needed to prevent any close contact with blower suction area.**

**Keep fingers and objects away from openings and rotating parts.**

**Product surfaces become very hot during operation, allow product surfaces to cool before handling.**

**Air stream from product may contain solid or liquid material that can result in eye or skin damage, wear proper eye protection.**

**Wear hearing protection. Sound level from some models may exceed 85 dBA.**

**Failure to follow these instructions can result in burns, eye injury or other serious injury.**

It is your responsibility to operate this product at recommended pressures or vacuum duties and room ambient temperatures. Do not operate R4P or larger size blowers without air flowing through the blower. Do not throttle discharge or suction pipe to reduce capacity. Throttle will increase differential pressure causing increasing power absorption and working temperatures.

**Start Up**

Operate blower for an hour and then check:

1. Ambient temperature – Check room and discharge air temperatures. Increased room temperatures may require stronger ventilation especially for larger blowers. Exhaust air should not exceed 215°F (102°C) for all blowers less than 3.5 Hp. Exhaust air should not exceed 275°F (135°C) for all blowers above 3.5 Hp.
2. Working pressure and vacuum values – Adjust relief valve pressure or vacuum setting, if needed.
3. Motor current – Check that supply current matches recommended current rating on product nameplate.
4. Electrical overload cutout – Check that current matches rating on product nameplate.

If motor fails to start or slows down significantly under load, shut off and disconnect from power supply. Check that the voltage is correct for motor and that motor is turning in the proper direction.

**FOR BLOWERS WITH GREASE FITTINGS**

Hours of Service Per Year	Relubrication Interval
5,000	3 years
Continual Normal Service	1 year
Seasonal Service (motor idle for 6 months or more)	1 year at beginning of season
Continuous-high ambients, dirty or moist applications	6 months

Check that all external accessories such as relief valves and gauges are not damaged before re-operating product.

## MAINTENANCE

 **WARNING**
**Electrical Shock Hazard**

Disconnect electrical power supply cord before performing maintenance on this product.

Some motors are thermally protected and will automatically re-start when protector resets. If product is hard wired into system, disconnect electrical power at the circuit breaker or fuse box before performing maintenance on this product.

Failure to follow these instructions can result in death, fire or electrical shock.

If the product is supplied with an electric power chord, protect it from twisting, cuts and abrasion. When not in use, store in a clean dry place.

 **WARNING**
**Injury Hazard**

**Product surfaces become very hot during operation, allow product surfaces to cool before handling.**

**Air stream from product may contain solid or liquid material that can result in eye or skin damage, wear proper eye protection.**

**Failure to follow these instructions can result in burns, eye injury or other serious injury.**

It is your responsibility to regularly inspect and make necessary repairs to this product in order to maintain proper operation. Make sure that pressure and vacuum is released from product before starting maintenance.

Check filter elements and noise absorbing foam used in mufflers and clean motor and blower after first 500 hours of operation. Replace filter elements and determine how frequently mufflers should be checked during future operation. This one procedure will help assure the product's performance and service life.

When there is an increase in the differential pressure across the inlet filter it is beginning to clog with dirt. Replace the cartridge when the filter will not come clean.

Small motor bearings (less than 5.5 Hp) never need to be greased. Larger motor bearings (greater than 5.5 Hp) have alerite grease fittings. Use a grease gun and apply one or two strokes of Exxon POLYREX® grease to the fittings to lubricate larger motor bearings.

**WARRANTY**

Gast finished products, when properly installed and operated under normal conditions of use, are warranted by Gast to be free from defects in material and workmanship for a period of twelve (12) months from the date of purchase from Gast or an authorized Gast Representative or Distributor. In order to obtain performance under this warranty, the buyer must promptly (in no event later than thirty (30) days after discovery of the defect) give written notice of the defect to Gast Manufacturing Incorporated, PO Box 97, Benton Harbor Michigan USA 49023-0097 or an authorized Service Center (unless specifically agreed upon in writing signed by both parties or specified in writing as part of a Gast OEM Quotation). Buyer is responsible for freight charges both to and from Gast in all cases.

This warranty does not apply to electric motors, electrical controls, and gasoline engines not supplied by Gast. Gast's warranties also do not extend to any goods or parts which have been subjected to misuse, lack of maintenance, neglect, damage by accident or transit damage.

THIS EXPRESS WARRANTY EXCLUDES ALL OTHER WARRANTIES OR REPRESENTATIONS EXPRESSED OR IMPLIED BY ANY LITERATURE, DATA, OR PERSON. GAST'S MAXIMUM LIABILITY UNDER THIS EXCLUSIVE REMEDY SHALL NEVER EXCEED THE COST OF THE SUBJECT PRODUCT AND GAST RESERVES THE RIGHT, AT ITS SOLE DISCRETION, TO REFUND THE PURCHASE PRICE IN LIEU OF REPAIR OR REPLACEMENT.

GAST WILL NOT BE RESPONSIBLE OR LIABLE FOR INDIRECT OR CONSEQUENTIAL DAMAGES OF ANY KIND, however arising, including but not limited to those for use of any products, loss of time, inconvenience, lost profit, labor charges, or other incidental or consequential damages with respect to persons, business, or property, whether as a result of breach of warranty, negligence or otherwise. Notwithstanding any other provision of this warranty, BUYER'S REMEDY AGAINST GAST FOR GOODS SUPPLIED OR FOR NON-DELIVERED GOODS OR FAILURE TO FURNISH GOODS, WHETHER OR NOT BASED ON NEGLIGENCE, STRICT LIABILITY OR BREACH OF EXPRESS OR IMPLIED WARRANTY IS LIMITED SOLELY, AT GAST'S OPTION, TO REPLACEMENT OF OR CURE OF SUCH NONCONFORMING OR NON-DELIVERED GOODS OR RETURN OF THE PURCHASE PRICE FOR SUCH GOODS AND IN NO EVENT SHALL EXCEED THE PRICE OR CHARGE FOR SUCH GOODS. GAST EXPRESSLY DISCLAIMS ANY WARRANTY OF MERCHANTABILITY OR FITNESS FOR A PARTICULAR USE OR PURPOSE WITH RESPECT TO THE GOODS SOLD. THERE ARE NO WARRANTIES WHICH EXTEND BEYOND THE DESCRIPTIONS SET FORTH IN THIS WARRANTY, notwithstanding any knowledge of Gast regarding the use or uses intended to be made of goods, proposed changes or additions to goods, or any assistance or suggestions that may have been made by Gast personnel.

Unauthorized extensions of warranties by the customer shall remain the customer's responsibility.

CUSTOMER IS RESPONSIBLE FOR DETERMINING THE SUITABILITY OF GAST PRODUCTS FOR CUSTOMER'S USE OR RESALE, OR FOR INCORPORATING THEM INTO OBJECTS OR APPLICATIONS WHICH CUSTOMER DESIGNS, ASSEMBLES, CONSTRUCTS OR MANUFACTURES.

This warranty can be modified only by authorized Gast personnel by signing a specific, written description of any modifications.

**ELECTRICAL WIRING DIAGRAMS**

<b>Models</b> R1102, R2103, R2105, R3105-1, R3105-12, R4110-2	
<b>Low Voltage Single Phase</b>	<b>High Voltage Single Phase</b>
Blue P1 ——— Line Brown P2 ——— Black 5 ——— Tie together Orange 3 ——— & Insulate White 2 ——— Yellow 4 ——— Tie together Line	P1 ——— Line P2 ——— Insulate 5 ——— 3 ——— Tie together 2 ——— & Insulate 4 ——— Line

<b>Models</b> R4P115, R5125-2, R6125-2	
<b>Low Voltage Single Phase</b>	<b>High Voltage Single Phase</b>
Purple ——— L1 Brown ——— Tie together Orange ——— & Insulate Blue ——— White ——— L2 Red ———	Purple ——— L1 Brown ——— Insulate White ——— Tie together Orange ——— & Insulate Blue ——— Red ——— L2

**Models**  
 R2303A, R3305A-1, R3305A-13, R4310A-2, R4P315A, R6350A-2, R6P350A, R6PP3110M, R6PS3110M,  
 R7100A-3, R7P3180M, R7S3180M, R93150A

**Note:** Model R6P355A has two additional leads labeled "J" for an external thermal motor protection circuit.

**Connections for 3-Phase, 9 Leads**

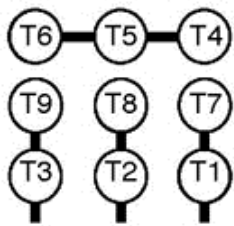

Line  
Low Voltage

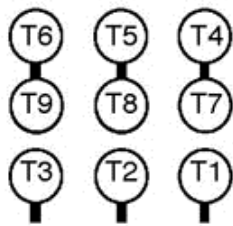

Line  
High Voltage

**Model R9P3300M, R93150A, R93150A-35**

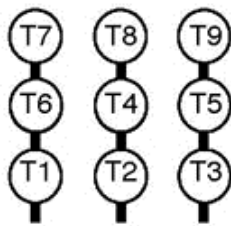

Line  
Low Voltage

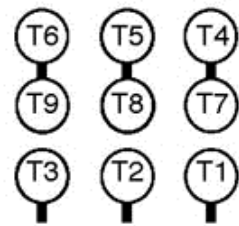

Line  
High Voltage

**Connections for 3-Phase, 12 Leads**  
**Models R6335A-2, R6P335A**

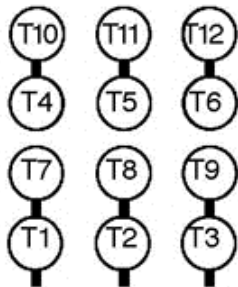

Line  
Low Voltage

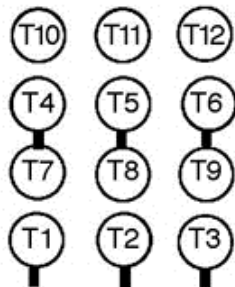

Line  
High Voltage

**Models R5325A-2, R6325A-2 (BEFORE 1-1-06)**

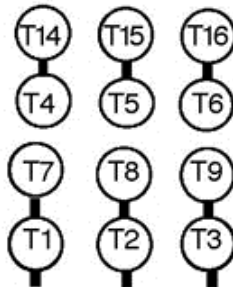

Line  
Low Voltage

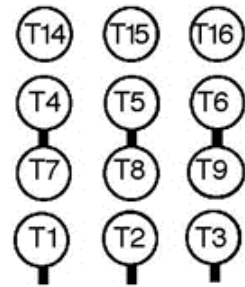

Line  
High Voltage

**Models R5325A-2, R6325A-2 (AFTER 1-1-06)**

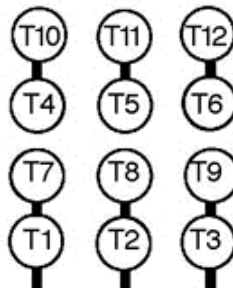

Line  
Low Voltage

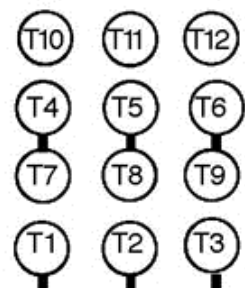

Line  
High Voltage

To reverse rotation on any 3-Phase motor, interchange any two external motor line connections to any two line leads.



**RECOMMENDED ACCESSORIES**

The following diagrams are only suggested configurations for these accessories. These accessory configurations may vary depending upon a particular unit's application.

**VACUUM ACCESSORIES**

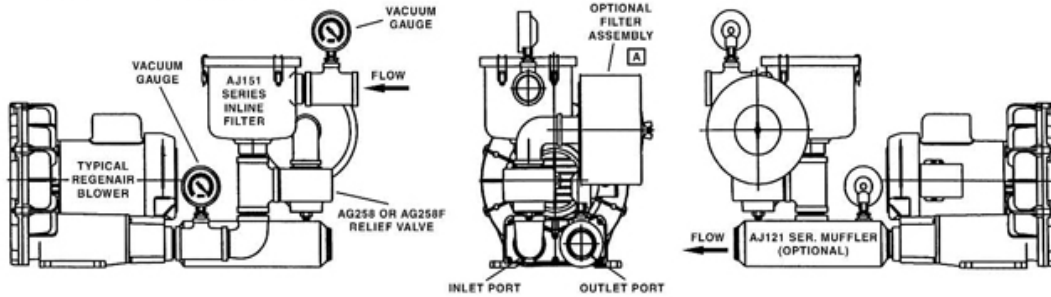

**PRESSURE ACCESSORIES**

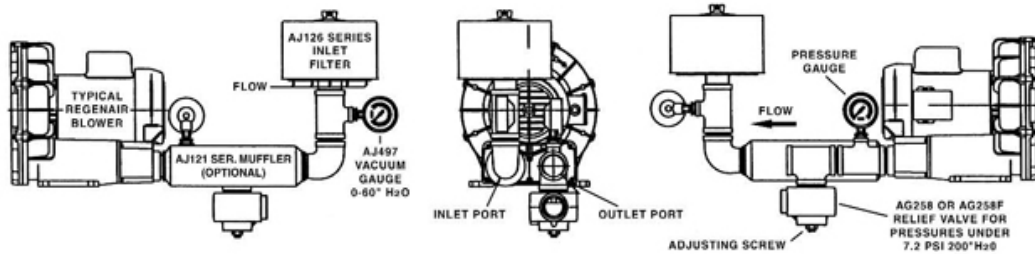

**MOISTURE SEPARATOR (FOR VACUUM)**

This moisture separator removes liquids from the gas stream in a vacuum process. This helps protect the blower from corrosion and the build up of mineral deposits.

For Model Number	R3, R4, R5	R4, R4H, R4P, R5	R4H, R4M, R5, R6, R6P, R6PS,	R4M, R6, R6P, R6PP, R7, R7P, R7S, R9, R9S
Part Number	RMS160	RMS200	RMS300	RMS400
CFM capacity	160	200	300	400
Liquid capacity (gal.)	10	19	19	40
Diameter (A)	14.8"	19.7"	19.7"	24"
Dimension (B)	37.5"	35"	35"	44"
NPT outlet (C)	2"	2"	2.5"	3"
Inlet diameter (D)	2"	2"	2.5"	3"
Dimension (E)	7.5"	7.5"	7.5"	9.7"
Dimension (F)	26.6"	26.6"	26.6"	29"

Maximum vacuum allowed: 22" Hg.

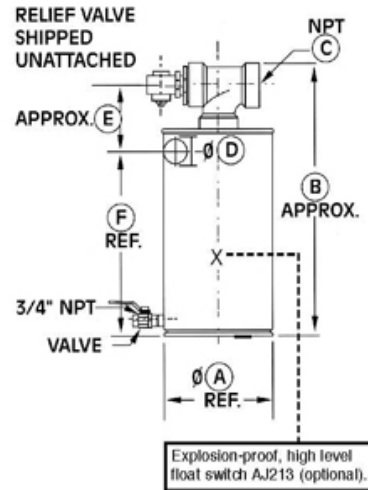

**HORIZONTAL SWING TYPE CHECK VALVE**

This check valve prevents backwash of fluids from entering the blower and air back-streaming. The check valve can be mounted to discharge or inlet either vertically or horizontally. The check valve will open with 3" of water pressure or vacuum.

Model Number	R1, R2	R3	R4, R5, SDR4, SDR4, R4P	R6, R6P, SDR6P, SDR6, R6PS	R7, R7S
Part Number	AH326B	AH326C	AH326D	AH326F	AH326G
Dimension (A)	3.57"	4.19"	4.50"	5.25"	8.00"
Dimension (B)	2.32"	2.69"	2.94"	3.82"	5.07"
Dimension (C)	1.00" NPT	1.25" NPT	1.50" NPT	2.00" NPT	2.50" NPT

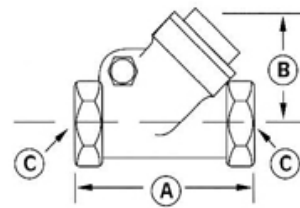

**PARTS & ORDERING INFORMATION**

Please reference the exploded view on the next page for the following model and parts tables.

REF#	ITEM	QTY	R3105-12 R3305A-13	R4110-2 R4310A-2 R4310B-1	R4P115 R4P315A†	R5125-2 R5325A-2 R5325B-1	R6125-2 R6150J-2 R6325A-2 R6335A-2 R6335B R6350A-2 R6350B-2	R6P335A R6P350A R6P350B	R6135J-10
1	COVER	1	AJ101C	AJ101D	AJ101L	AJ101EQ	AJ101FB	AJ101K	AJ101FB
2	LOCK NUT	1	BC181	BC181	BC181	AJ259	AJ259	AJ259	AJ259
3	IMPELLER	1	AJ102CA	AJ102D	AJ102L	AJ102E	AJ102FR	AJ102K	AJ102FR
4	SQUARE KEY	1	AB136A	AB136D	AB136D	AB136	AB136	AB136	AB136
5	SHIM SPACER	Δ	AJ109	AJ109	AJ109	AJ109	AJ109	AJ109	AJ260A
5†	SHIM SPACER†	1	-	-	AJ109A†	-	-	-	-
6	RETAINING RING	1	AJ149	AJ149	AJ149	-	-	-	-
7	HOUSING	1	AJ103C	AJ103DR	AJ103L	AJ103EQ	AJ103FQ	AJ103K	AJ103FQ
8	MUFFLER BOX	1	-	-	-	-	-	AJ104K	-
9	SPRING	2	-	AJ113DR	AJ113DQ	AJ113DQ	AJ113FQ	AJ113FQ	AJ113FQ
9A	SCREEN	2	-	-	AJ123EQ	AJ123EQ	AJ123FB	-	AJ123FB
10A	FOAM	Δ	AJ112C(4)	AJ112DS(4)	AJ112ER(6)	AJ112ER(6)	AJ112FC(6)	AJ112K(8)	AJ112FC(6)
10B	FOAM	2	AJ112CQ	AJ112DR	-	-	-	-	-
11	MUFFLER EXTENSION	1	AJ106CQ	AJ106DQ	AJ106EQ	AJ106EQ	AJ106FR	-	AJ106FR

REF#	ITEM	QTY	R6P355A R6P350A R6P350B	R6PP3110M*	R6PS3110M*	R7100A-3	R7100B-1
1	COVER	1	AJ101K	AJ101KA(2)	AJ101KA(2)	AJ101G	AJ101G
2	LOCK NUT/BOLT	1	AJ259	BB750(2)	BB750(2)	BB750	BB750
3	IMPELLER	1	AJ102K	AJ102KA(2)	AJ102KA(2)	AJ102GZ	AJ102GA
4	SQUARE KEY	1	AB136	AB136(2)	AB136(2)	AC628	AC628
5	SHIM SPACER	Δ	AJ109	AJ169F	AJ169F	AJ110	AJ110
6	RETAINING RING	1	-	-	-	-	-
7	HOUSING	1	AJ103K	AJ103KD(2)	AJ103KD(2)	AJ103GA	AJ103GA
8	MUFFLER BOX	1	AJ104K	-	-	AJ104GA	AJ104GA
8A	SCREEN	2	-	-	-	AJ998G	AJ998G
9	SPRING	2	AJ113FQ	-	-	-	-
10A	FOAM	Δ	AJ112K(8)	-	-	AJ112GA(8)	AJ112GA(8)
10B	FOAM	2	-	-	-	-	-
11	MUFFLER EXTENSION	1	-	-	-	-	-
12 **	O-RING	2	-	AJ175	-	-	-
13	GASKET	4	-	AJ107F	AJ107F	-	-

REF#	ITEM	QTY	R7P3180M*	R7S3180M*	R9P3300M*	R9S3300M*	R93150A
1	COVER	1	AJ101G(2)	AJ101G(2)	AJ101M(2)	AJ101M(2)	AJ101M
2	LOCK NUT/BOLT	1	BB750(2)	BB750(2)	BB707(2)	BB707(2)	BB707
3	IMPELLER	1	AJ102GZ(2)	AJ102GZ(2)	AJ102M(2)	AJ102M(2)	AJ102M
4	SQUARE KEY	1	AC628(2)	AC628(2)	AE130A(2)	AE130A(2)	AE130A
5	SHIM SPACER	Δ	AJ110	AJ110	BJ110	BJ110	BJ110A
6	RETAINING RING	1	-	-	-	-	-
7	HOUSING	1	AJ103GA(2)	AJ103GA(2)	AJ103M(2)	AJ103M(2)	AJ103M
8	MUFFLER BOX	1	-	-	-	-	AJ104MP
8A	SCREEN	2	-	-	-	-	AJ998M
9	SPRING	2	-	-	-	-	-
10A	FOAM	Δ	-	-	-	-	AJ112M(10)
10B	FOAM	2	-	-	-	-	-
11	MUFFLER EXTENSION	1	-	-	-	-	-
12 **	O-RING	2	AJ175G	-	AJ175G	-	-

† R4P315A only.

\* Dual models.

\*\* Not shown.

Δ As required.

Parts listed are for stock models. For specific OEM models, please consult the factory.  
When corresponding or ordering parts, please give complete model and serial numbers.

**EXPLODED PRODUCT VIEW**

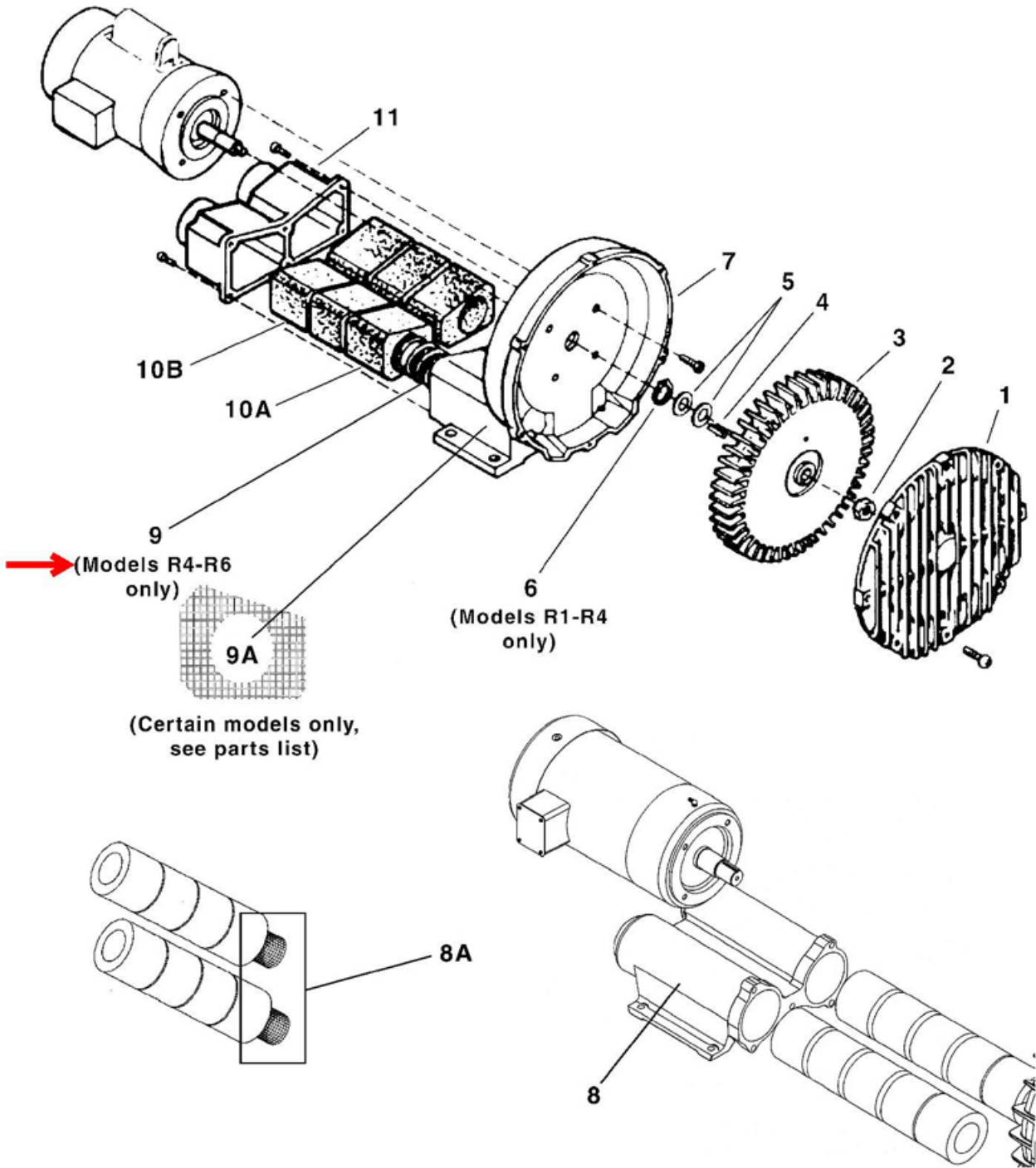



### TROUBLESHOOTING CHART

Problem	Reason	Remedy
Increased sound.	Noise absorbing foam is damaged. Impeller rubbing inside.	Replace foam. Send unit to a Gast Authorized Service Facility.
Excessive vibration.	Damaged impeller. Motor and/or impeller are dirty.	Replace impeller. Clean motor and impeller periodically.
Ambient and exhaust temperature increases.	Motor and/or blower are dirty. Filters dirty.	Clean motor and blower periodically. Replace filters.
Decreased inlet air pressure	Inlet air filter is clogged.	Clean inlet filter. Replace cartridge.
Unit is very hot.	Wrong wiring. Low voltage. Inlet air filter is clogged. Motor and/or blower are dirty. Operating at too high a pressure or vacuum.	Check wiring. Supply proper voltage. Clean inlet filter. Replace cartridge. Clean motor and blower periodically. Install a relief valve and pressure or vacuum gauge.
Unusual sound.	Impeller is damaged or dirty. Bearing going bad.	Clean or replace impeller. Send unit to a Gast Authorized Service Facility.
Motor overload	Low voltage.	Check power source. Check wire size and wire connections.
Unit does not start.	Incorrect electrical connection or power source. Impeller is damaged.	Check wiring diagram, circuit fusing and circuit capacity. Clean or replace impeller. Install proper filtration.

**We have Gast Certified Service Centers throughout the world. For the most up-to-date listing, contact one of our sales offices below:**

**World Headquarters**

P.O. Box 97  
2550 Meadowbrook Rd.  
Benton Harbor, MI 49023-0097  
Ph: 269/926-6171  
FAX: 269/925-8288  
www.gastmfg.com

**Gast Hong Kong**

Unit 12, 21/F, Block B  
New Trade Plaza  
6, On Ping Street, Shatin  
N. T. Hong Kong  
Ph: (852) 2690 1008  
Fax: (852) 2690 1012  
www.gasthk.com



ISO 9001 & 14001 CERTIFIED

[www.gastmfg.com](http://www.gastmfg.com)

**FILTER/REGULATOR**



**Integrated filter and regulator units save space and require less piping.**

Direct operated, relieving type

JIS Symbol

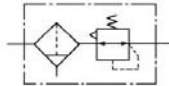

P. 14-2-72



AW20



AW40

**How to Order**



Filter regulator

Body size

10 20 30 40

Thread type

Nil	Metric thread (M5)
N (1)	Rc
N (1)	NPT
F (2)	G

Note 1) Drain guide is NPT 1/4 (applicable to AW30 and 40), and the exhaust port for auto-drain comes with ø3/8" One-touch fitting (applicable to AW30 and AW40).

Note 2) Drain guide is G 1/4 (applicable to AW30 and AW40).

Port size

Symbol	Port size	Body size			
		10	20	30	40
M5	M5	●	—	—	—
01	1/8	—	●	—	—
02	1/4	—	●	●	●
03	3/8	—	—	●	●
04	1/2	—	—	—	●
06	3/4	—	—	—	●

Option

Symbol	Description	Applicable model
1 (5)	0.02 to 0.2 MPa setting	AW10 to 40
2	Metal bowl	AW10 to 40
6	Nylon bowl	AW10 to 40
8	Metal bowl with level gauge	AW30/40
C	With bowl guard	AW20
J (6)	Drain guide 1/4	AW30/40
N	Non-relieving	AW10 to 40
R	Flow direction: Right → Left	AW10 to 40
W	Drain cock with barb fitting: ø6 x ø4 nylon tubing	AW30/40
Z (7)	Name plate, caution plate for bowl, and pressure gauge in imperial units (PSI, °F)	AW10 to 40

\* When more than one specification is required, indicate in alphanumeric order.

Note 5) The only difference from the standard specifications is the adjusting spring for the regulator. It does not restrict the setting of 0.2 MPa or more.

Note 6) Without a valve function.

Note 7) For M5 and NPT thread types. This product is for overseas use only according to the new Measurement Law. (The SI unit type is provided for use in Japan.)

Accessory (3)

Symbol	Description	Applicable model
Nil	—	—
B	With bracket	AW10 to 40
C	Float type auto-drain (N.C.) (4)	AW10 to 40
D	Float type auto-drain (N.O.) (4)	AW30/40
E	With square embedded type pressure gauge (With limit indicator)	AW20 to 40
G	With round pressure gauge (Without limit indicator)	AW10
	With round pressure gauge (With limit indicator)	AW20 to 40
H	With set nut (For panel mount)	AW10 to 40

Note 3) Optional parts are not assembled and are supplied loose at the time of shipment (except options C, D and E).

Note 4) Applicable tubing O.D for auto drain connection should be ø3/8" in case NPT thread port is chosen.

**Accessory/Optional Specifications Combinations**

⊙: Combination available

■: Combination not available

○: Varies depending on the model

△: Available only with NPT thread

Accessory/Optional specifications	Combination Symbol	Accessory											Optional specifications							Applicable filter regulator					
		B	C	D	E	G	H	1	2	6	8	C	J	N	R	W	Z	AW10	AW20	AW30 to 40					
Accessory	With bracket (With set nut)	⊙	⊙	⊙	⊙	⊙	⊙	⊙	⊙	⊙	⊙	⊙	⊙	⊙	⊙	⊙	⊙	⊙	⊙	⊙	⊙	⊙	⊙	⊙	
	Float type auto-drain (N.C.)	⊙	⊙	⊙	⊙	⊙	⊙	⊙	⊙	⊙	⊙	⊙	⊙	⊙	⊙	⊙	⊙	⊙	⊙	⊙	⊙	⊙	⊙	⊙	
	Float type auto-drain (N.O.)	⊙	⊙	⊙	⊙	⊙	⊙	⊙	⊙	⊙	⊙	⊙	⊙	⊙	⊙	⊙	⊙	⊙	⊙	⊙	⊙	⊙	⊙	⊙	
	Square embedded type pressure gauge	⊙	⊙	⊙	⊙	⊙	⊙	⊙	⊙	⊙	⊙	⊙	⊙	⊙	⊙	⊙	⊙	⊙	⊙	⊙	⊙	⊙	⊙	⊙	
	Round pressure gauge	⊙	⊙	⊙	⊙	⊙	⊙	⊙	⊙	⊙	⊙	⊙	⊙	⊙	⊙	⊙	⊙	⊙	⊙	⊙	⊙	⊙	⊙	⊙	
	With set nut (For panel mount)	⊙	⊙	⊙	⊙	⊙	⊙	⊙	⊙	⊙	⊙	⊙	⊙	⊙	⊙	⊙	⊙	⊙	⊙	⊙	⊙	⊙	⊙	⊙	
Optional specifications	0.02 to 0.2 MPa setting	⊙	⊙	⊙	⊙	⊙	⊙	⊙	⊙	⊙	⊙	⊙	⊙	⊙	⊙	⊙	⊙	⊙	⊙	⊙	⊙	⊙	⊙	⊙	
	Metal bowl	⊙	⊙	⊙	⊙	⊙	⊙	⊙	⊙	⊙	⊙	⊙	⊙	⊙	⊙	⊙	⊙	⊙	⊙	⊙	⊙	⊙	⊙	⊙	
	Nylon bowl	⊙	⊙	⊙	⊙	⊙	⊙	⊙	⊙	⊙	⊙	⊙	⊙	⊙	⊙	⊙	⊙	⊙	⊙	⊙	⊙	⊙	⊙	⊙	
	Metal bowl with level gauge	⊙	⊙	⊙	⊙	⊙	⊙	⊙	⊙	⊙	⊙	⊙	⊙	⊙	⊙	⊙	⊙	⊙	⊙	⊙	⊙	⊙	⊙	⊙	
	With bowl guard	⊙	⊙	⊙	⊙	⊙	⊙	⊙	⊙	⊙	⊙	⊙	⊙	⊙	⊙	⊙	⊙	⊙	⊙	⊙	⊙	⊙	⊙	⊙	
	Drain guide 1/4	⊙	⊙	⊙	⊙	⊙	⊙	⊙	⊙	⊙	⊙	⊙	⊙	⊙	⊙	⊙	⊙	⊙	⊙	⊙	⊙	⊙	⊙	⊙	
	Non-relieving type	⊙	⊙	⊙	⊙	⊙	⊙	⊙	⊙	⊙	⊙	⊙	⊙	⊙	⊙	⊙	⊙	⊙	⊙	⊙	⊙	⊙	⊙	⊙	
	Flow direction: Right → Left	⊙	⊙	⊙	⊙	⊙	⊙	⊙	⊙	⊙	⊙	⊙	⊙	⊙	⊙	⊙	⊙	⊙	⊙	⊙	⊙	⊙	⊙	⊙	
	Drain cock with barb fitting: ø6 x ø4 nylon tubing	⊙	⊙	⊙	⊙	⊙	⊙	⊙	⊙	⊙	⊙	⊙	⊙	⊙	⊙	⊙	⊙	⊙	⊙	⊙	⊙	⊙	⊙	⊙	⊙
	Name plate, caution plate for bowl, and pressure gauge in imperial units (PSI, °F)	△	△	△	△	△	△	△	△	△	△	△	△	△	△	△	△	△	△	△	△	△	△	△	△

## Standard Specifications

Model	AW10	AW20	AW30	AW40	AW40-06
Port sizes	M5 x 0.8	1/8, 1/4	1/4, 3/8	1/4, 3/8, 1/2	3/4
Fluid	Air				
Proof pressure	1.5 MPa				
Maximum operating pressure	1.0 MPa				
Set pressure range	0.05 to 0.85 MPa				
Pressure gauge port size <sup>(1)</sup>	Rc 1/16 <sup>(2)</sup>	Rc, NPT, G 1/8	Rc, NPT, G 1/8	Rc, NPT, G 1/4	Rc, NPT, G 1/4
Relief pressure	Set pressure + 0.05 MPa <sup>(3)</sup> (at relief flow rate of 0.1 l/min (ANR))				
Ambient and fluid temperature	-5 to 60°C (With no freezing)				
Nominal filtration rating	5 µm				
Drain capacity (cm <sup>3</sup> )	2.5	8	25	45	45
Bowl material	Polycarbonate				
Bowl guard	—	Option	Standard		
Construction	Relieving type				
Weight (kg)	0.09	0.32	0.40	0.72	0.75

Note 1) Pressure gauge connection threads are not required for regulators with a square embedded type pressure gauge (AW20 to AW40).

Note 2) Use a bushing (part no: 131368) when connecting R 1/8 pressure gauge to R 1/16 gauge port.

Note 3) Not applicable to AW10.

## Accessory Part No.

Applicable model		AW10	AW20	AW30	AW40	AW40-06			
Accessory									
Bracket assembly <sup>(1)</sup>		AR10P-270AS	AW20P-270AS	AR30P-270AS	AR40P-270AS	AR40P-270AS			
Set nut		AR10P-260S	AR20P-260S	AR30P-260S	AR40P-260S	AR40P-260S			
Pressure gauge <sup>(2)</sup>	1.0 MPa	Round Type	G27-10-R1	G36-10-□01	G36-10-□01	G46-10-□02	G46-10-□02		
		Square embedded type <sup>(4)</sup>	—	GC3-10AS	GC3-10AS	GC3-10AS	GC3-10AS		
	0.2 MPa	Round Type	G27-10-R1 <sup>(3)</sup>	G36-2-□01	G36-2-□01	G46-2-□02	G46-2-□02		
		Square embedded type <sup>(4)</sup>	—	GC3-2AS	GC3-2AS	GC3-2AS	GC3-2AS		
Float type auto-drain <sup>(5)</sup>	N.O.	—	—	AD38	AD38N <sup>(6)</sup>	AD48	AD48N <sup>(6)</sup>	AD48	AD48N <sup>(6)</sup>
	N.C.	AD17	AD27	AD37	AD37N <sup>(6)</sup>	AD47	AD47N <sup>(6)</sup>	AD47	AD47N <sup>(6)</sup>

Note 1) Assembly includes a bracket and set nuts.

Note 2) □ in part numbers for a round pressure gauge indicates a type of connection thread. No indication is necessary for R; however, indicate N for NPT. Please contact SMC regarding the connection thread NPT and supply of the pressure gauge for PSI unit specifications.

Note 3) For 1 MPa.

Note 4) Includes one O-ring and 2 mounting screws.

Note 5) Minimum operating pressure: N.O. type—0.1 MPa; N.C. type—0.1 MPa (AD17/27) and 0.15 MPa (AD37/47). Please contact SMC regarding the specifications for PSI unit and °F.

Note 6) When "N" is specified in the end of part number of auto-drain, applicable tubing O.D should be ø3/8".

## ⚠ Precautions

Be sure to read before handling. Refer to pages 14-21-3 to 14-21-4 for Safety Instructions and Common Precautions.

### Selection

#### ⚠ Warning

- Residual pressure release (outlet pressure release) is not completed by releasing inlet pressure. To release residual pressure, use a filter regulator with a back flow mechanism.

### Maintenance

#### ⚠ Warning

- Replace the element every 2 years or when the pressure drop becomes 0.1 MPa, whichever comes first, to prevent damage to the element.

### Mounting & Adjustment

#### ⚠ Warning

- Set the regulator while checking the displayed values of the inlet and outlet pressure gauges. Turning the knob excessively can cause damage to the internal parts.
- The pressure gauge indicated with regulators for 0.02 to 0.2 MPa setting is for 0.2 MPa use only. Exceeding 0.2 MPa of pressure can damage the gauge.
- Do not use tools on the pressure regulator knob as this may cause damage. It must be operated manually.

#### ⚠ Caution

- Be sure to unlock the knob before adjusting the pressure and lock it after setting the pressure. Failure to follow this procedure can cause damage to the knob and the outlet pressure may fluctuate.

- Pull the pressure regulator knob to unlock. (You can visually verify this with the "orange mark" that appears in the gap.)
- Push the pressure regulator knob to lock. When the knob is not easily locked, turn it left and right a little and then push it (when the knob is locked, the "orange mark" will disappear).



- A knob cover is available to prevent careless operation of the knob. Refer to page 14-2-6 for details.



**Flow Characteristics** (Representative values)

Condition: Inlet pressure 0.7 MPa

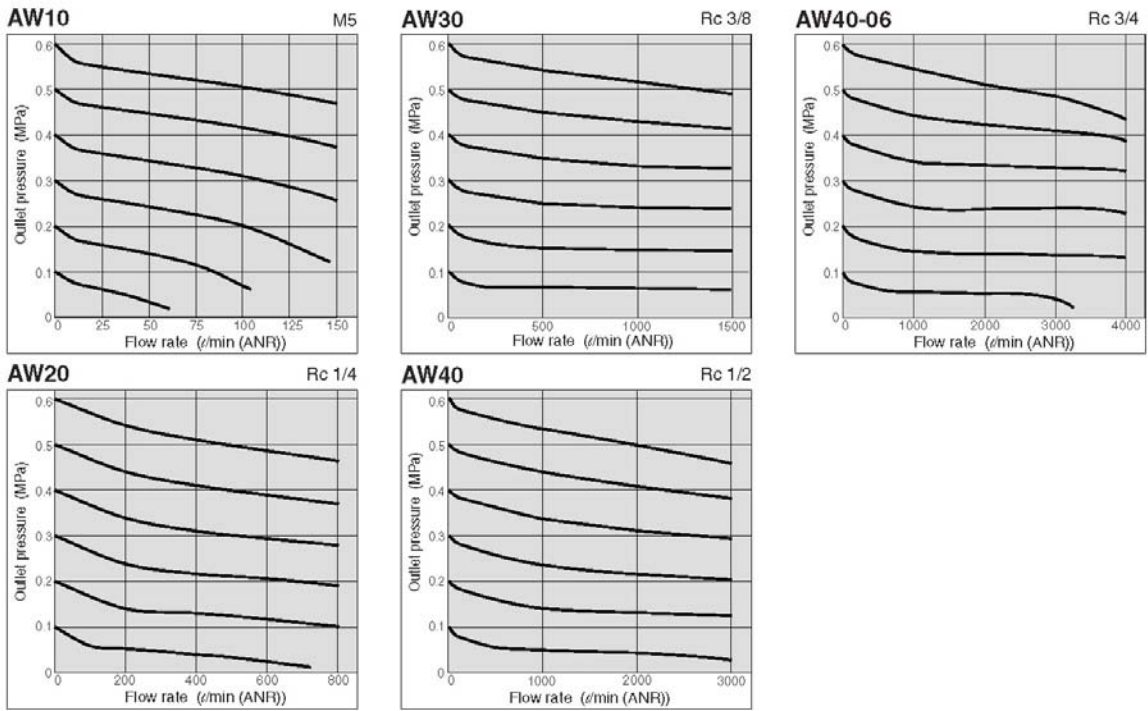

**Pressure Characteristics** (Representative value)

Conditions: Inlet pressure 0.7 MPa; Outlet pressure 0.2 MPa; Flow rate 20 l/min (ANR)

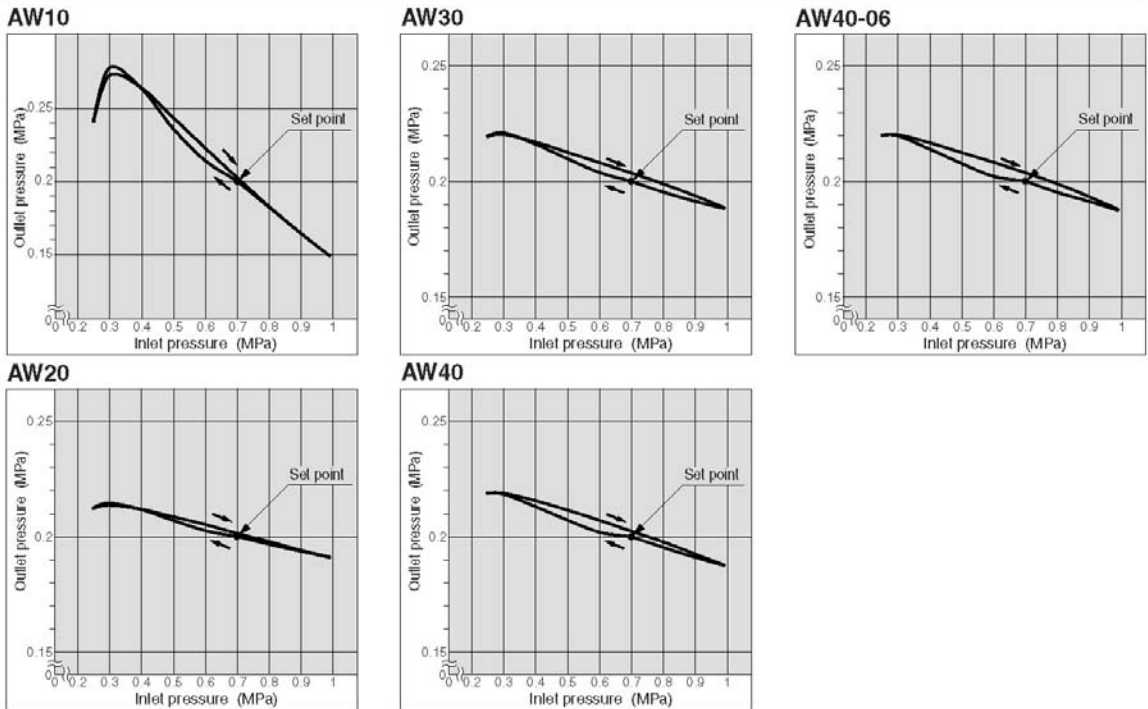

## Construction

JIS Symbol

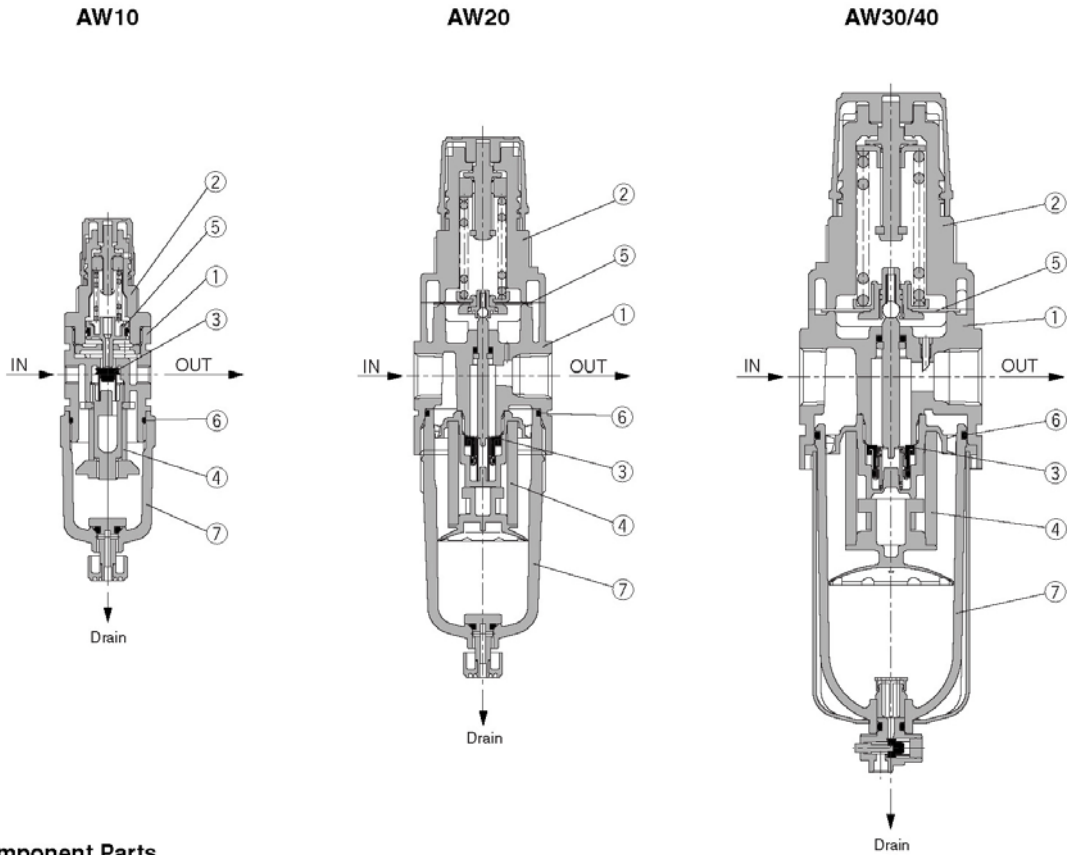
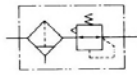

### Component Parts

No.	Description	Material		Note
		AW10/20	AW30 AW40/40-06	
①	Body	Zinc die-casted	Aluminum die-casted	Platinum silver
②	Bonnet	Polyacetal		Black

### Replacement Parts

No.	Description	Material	Part no.				
			AW10	AW20	AW30	AW40 AW40-06	
③	Valve assembly	Stainless steel Brass, HNBR	AR10P-090S	AW20P-360AS <sup>(4)</sup>	AW30P-360AS <sup>(4)</sup>	AW40P-360AS <sup>(4)</sup>	AW40P-380AS <sup>(4)</sup>
④	Filter element	Non-woven fabric	AF10P-060S	AF20P-060S	AF30P-060S	AF40P-060S	AF40P-060S
⑤	Diaphragm assembly	Weatherability NBR	AR10P-150AS <sup>(1)</sup>	AR20P-150AS	AR30P-150AS	AR40P-150AS	AR40P-150AS
⑥	Bowl O-ring	NBR	C1SFP-260S	C2SFP-260S	C3SFP-260S	C4SFP-260S	C4SFP-260S
⑦	Bowl assembly <sup>(2)</sup>	PC	C1SF	C2SF	C3SF <sup>(3)</sup>	C4SF <sup>(3)</sup>	C4SF <sup>(3)</sup>

Note 1) AW10 is a piston and a gasket (KSY-P-13) type assembly.

Note 2) Including O-ring. Please contact SMC regarding the bowl assembly supply for PSI and °F unit specifications.

Note 3) Bowl assembly includes a bowl guard (steel band material).

Note 4) Assembly includes valve assembly, valve spring and stem assembly.

## Dimensions

### AW10/20

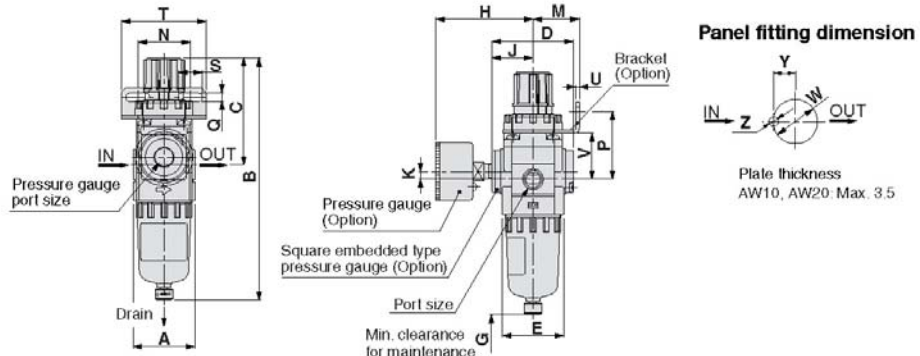

### AW30/40

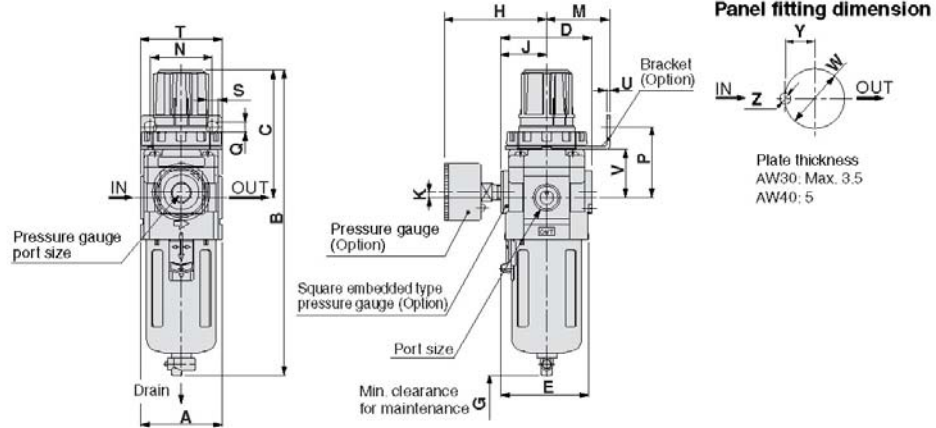

Applicable model	AW10, AW20				AW30, AW40, AW40-06						
	With auto-drain (N.C.)	Metal bowl	With auto-drain (N.O./N.C.)	Metal bowl	Metal bowl with level gauge	With drain guide	Drain cock with barb fitting				
Optional specifications	M5 x 0.8		N.O.: Black N.C.: Gray ø10 One-touch fitting			1/4 Width across flats 17	Barb fitting Applicable tubing: T0604				

(mm)

Model	Port size	Standard specifications															Accessory specifications						
		A	B	C	D	E	G	With pressure gauge			Bracket mounting size					Panel mount			With auto-drain				
								H	J	K	M	N	P	Q	S	T	U	V		W	Y	Z	B
AW10	M5 x 0.8	25	108	48	25	28	25	26	—	0	25	28	30	4.5	6.5	40	2	18	18.5	—	—	125	
AW20	1/8, 1/4	40	160	73	52	40	40	63	27	5	30	34	44	5.4	15.4	55	2.3	30	28.5	14	6	177	
AW30	1/4, 3/8	53	201	86	59	57	55	66	30.5	3.5	41	40	46	6.5	8	53	2.3	31	38.5	19	7	242	
AW40	1/4, 3/8, 1/2	70	239	92	75	73	80	76	38.5	1.5	50	54	54	8.5	10.5	70	2.3	35.5	42.5	21	7	278	
AW40-06	3/4	75	242	93	75	73	80	76	38.5	1.2	50	54	56	8.5	10.5	70	2.3	37	42.5	21	7	281	

Model	Optional specifications			
	With barb fitting	With drain guide	Metal bowl	Metal bowl with level gauge
	B	B	B	B
AW10	—	—	107	—
AW20	—	—	160	—
AW30	209	208	214	234
AW40	247	246	252	272
AW40-06	250	249	255	275



## WATER SEPARATOR

The AMG series water separator is installed on the air pressure line to remove water drops in the compressed air. It is suitable for use in cases where "water must be removed, but the air does not have to be as dry as when an air dryer is used" or "an air dryer cannot be used because an electric power supply is not available".

Through the adoption of an element that is used exclusively for removing water drops and the provision of ample housing interior space, a 99%\* water removal rate\*\* has been achieved.

### ⚠ Caution

Water separator can remove water droplets, but it cannot remove moisture.

- \*Condition of inlet air
  - Pressure: 0.7 MPa
  - Temperature: 25°C
  - Relative humidity: 100%
  - Liquid water content (Water droplet content): 1.5 g/m<sup>3</sup> (ANR)
  - Compressed air flow: Rated flow of each model
- \*\*Removed rate of water (%) =

$$\frac{\text{Removed water (Water droplet) (g)}}{\text{Inflow water (Water droplet) (g)}} \times 100$$

Various equipment for drain discharge

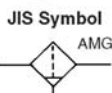

**Made to Order** Made to Order Specifications (For details, refer to page 14-20-55.)

### ⚠ Caution

Be sure to read before handling. Refer to pages 14-21-3 to 4 for Safety Instructions and Common Precautions on the products mentioned in this catalog, pages 14-14-6 to 8 for Precautions on every series, and pages 14-20-62 to 64 for more detailed precautions on every series.

### Model

Model	AMG150	AMG250	AMG350	AMG450	AMG550	AMG650	AMG850
Rated flow (ℓ/min (ANR)) <small>Note)</small>	300	750	1500	2200	3500	6000	12000
Port size (Nominal size B)	1/8, 1/4, 3/8	1/4, 3/8, 1/2	3/8, 1/2, 3/4	1/2, 3/4, 1	3/4, 1	1, 1 1/2	1 1/2, 2
Weight (kg)	0.38	0.55	0.9	1.4	2.1	4.2	10.5

Note) Max. flow capacity at a pressure of 0.7 MPa. Max. flow varies depending on operating pressure. Refer to page 14-20-4 for flow rate and page 14-20-4 for the max. flow line graph.

### Specifications

Fluid	Compressed air
Max. operating pressure	1.0 MPa
Min. operating pressure *	0.05 MPa
Proof pressure	1.5 MPa
Ambient and fluid temperature	5 to 60°C
Removed rate of water	99%
Element life	2 years or when pressure drop reaches 0.1 MPa

\* 0.1 MPa (N.O. type) or 0.15 MPa (N.C. type) in the case of types with auto-drain.

Refer to "Made to Order Specifications" on page 14-20-55.

### Accessory (Option)

Applicable model	AMG150	AMG250	AMG350	AMG450	AMG550	AMG650	AMG850
Bracket assembly (With cap bolt and spring washer)	BM51	BM52	BM53	BM54	BM55	BM56	BM57

### How to Order

AMG 250 03 B J

Body size

150	1/8 Standard
250	1/4 Standard
350	3/8 Standard
450	1/2 Standard
550	3/4 Standard
650	1 Standard
850	1 1/2 Standard

Thread type

Nil	Rc
F	G
N	NPT

Port size

01	1/8 <sup>B</sup>	06	3/4 <sup>B</sup>
02	1/4 <sup>B</sup>	10	1 <sup>B</sup>
03	3/8 <sup>B</sup>	14	1 1/2 <sup>B</sup>
04	1/2 <sup>B</sup>	20	2 <sup>B</sup>

Option \*

J	Drain guide 1/4 <sup>B</sup> female thread
R	IN-OUT reversal direction

Note) Element service indicator (symbol: T) is not available as an option because water deposits inside the indicator will lead to malfunctions.

### Accessory (Option) \*

Symbol	Description
Nil	—
B	Bracket
C	N.C. auto-drain
D	N.O. auto-drain

\* Refer to the table below for accessory/Option combinations.

Note) Refer to "How to Order Bowl Assembly" on page 14-20-59.

### Accessory/Option Combinations

● Available □ Not available ○ Depends on model

Accessory (Option)	Accessory specifications	Applicable model										
		C	D	J	R	AMG150	AMG250	AMG350	AMG450	AMG550	AMG650	AMG850
Accessory	N.C. auto-drain	C	□	□	□	○	○	○	○	○	○	○
	N.O. auto-drain	D	□	□	□	○	○	○	○	○	○	○
Option	Drain guide 1/4 B	-J	○	○	○	○	○	○	○	○	○	○
	IN-OUT reversal direction	-R	○	○	○	○	○	○	○	○	○	○

**Flow Characteristics**

Element initial condition

Note) Compressed air over max. flow line in the table below may not meet the specifications of the product. It may cause damage to the element.

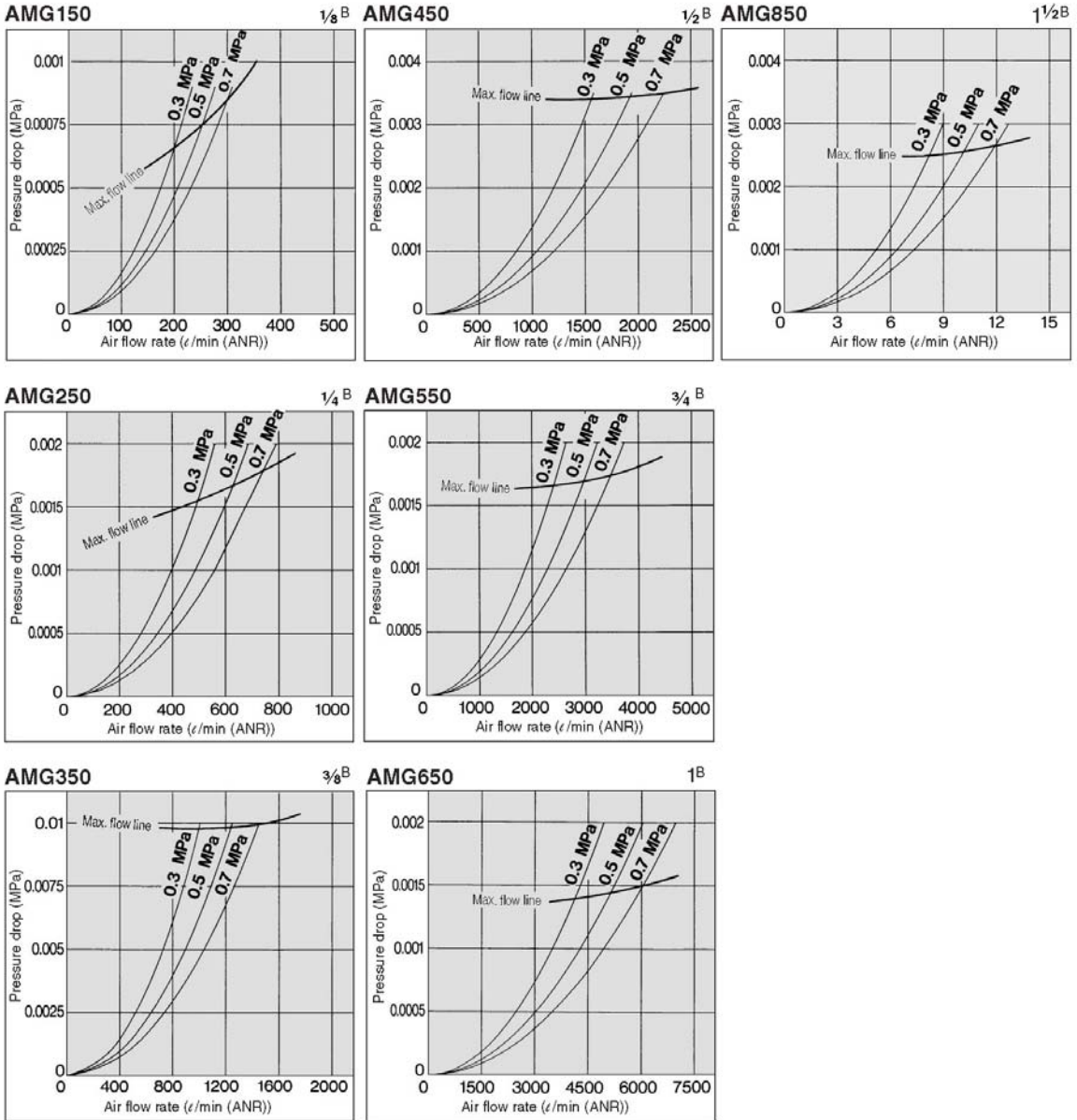

**Construction**

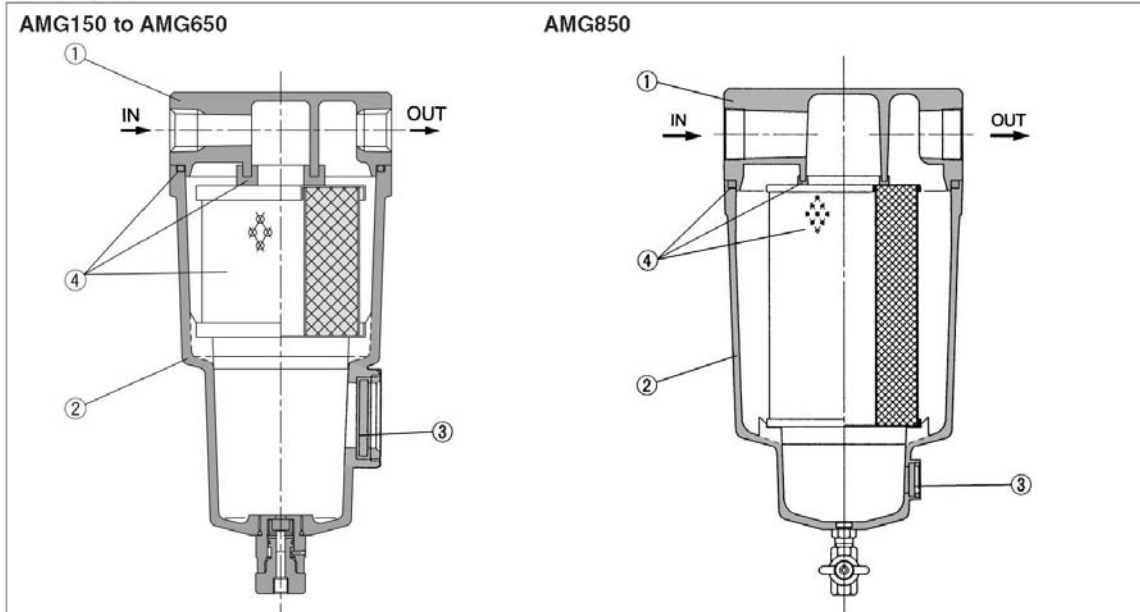

**Component Parts**

No.	Description	Material	Note
①	Body	Aluminum die-casted	Chrome treated
②	Housing	Aluminum die-casted*	Epoxy coating on inner surface
③	Sight glass	Tempered glass	

\* AMG850 is aluminum casted.



Note) Refer to page 14-20-59 for "How to Order Bowl Assembly".



Note) Sight glass is indicated in the figure above for easy understanding of parts, however mounting position is different. Refer to dimensions on pages 14-20-6 to 7 for details.

**Replacement Parts**

No.	Description	Material	Model						
			AMG150	AMG250	AMG350	AMG450	AMG550	AMG650	AMG850
④	Element assembly	Resin Others	AMG-EL150	AMG-EL250	AMG-EL350	AMG-EL450	AMG-EL550	AMG-EL650	AMG-EL850

\* Element assembly: With gasket and O-ring

**Max. Air Flow**

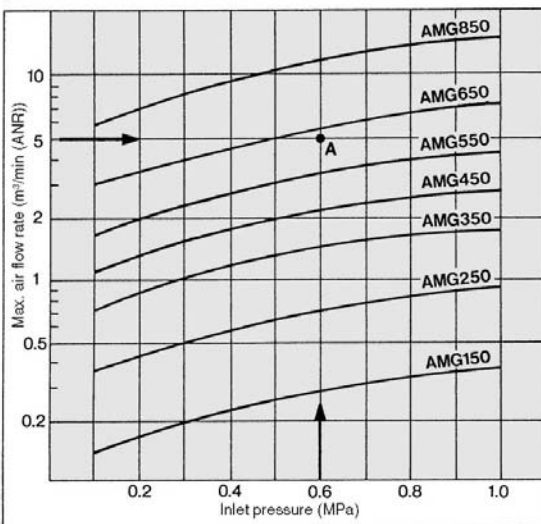

**Model Selection**

Select the model in accordance with the following procedure taking the inlet pressure and max. air flow into consideration.

(Example) Inlet pressure: 0.6 MPa

Maximum air flow rate: 5 m<sup>3</sup>/min (ANR)

1. Select the point of contact A of inlet pressure and max. air capacity in the graph.
2. AMG650 is obtained when the max. flow line is above the point of intersection A in the graph.



Note) Make sure to select a model that has the maximum flow rate line above the obtained intersecting point. With a model that has the maximum flow rate line below the obtained intersecting point, the flow rate will be exceeded, thus leading to a problem such as being unable to satisfy the specifications.

**AMG150 to AMG650 Dimensions**

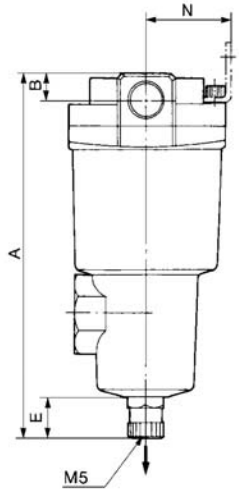
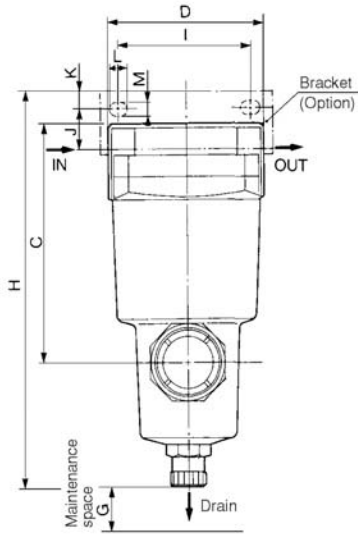
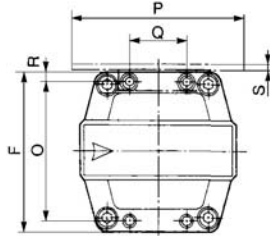

**Accessory**

**D: With auto-drain (N.O.)**

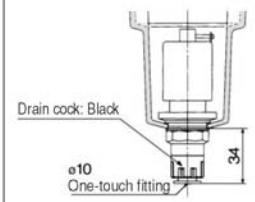

**C: With auto-drain (N.C.)**

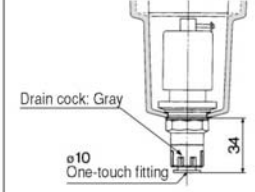

\* N.C. auto-drain not available for AMG650.

**Option**

**J: With drain guide**

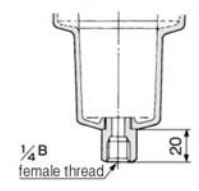

Model	Port size (Nominal size B)	A	B	C	D	E	F	G	Dimensions with mounting bracket											
									H	I	J	K	L	M	N	O	P	Q	R	S
AMG150	1/8, 1/4, 3/8	159	13	100	63	20	63	10	166	56	15	5	9	5.5	35	54	70	26	4.5	1.6
	1/4, 3/8	172	13	113	76	20	76	10	187	66	20	8	12	6	40	66	84	28	5	2.0
AMG250	1/2	178	16	119	76	20	76	10	187	66	17	8	12	6	40	66	84	28	5	2.0
	3/8, 1/2	204	16	145	90	20	90	10	218	80	22	8	14	7	50	80	100	34	5	2.3
AMG350	3/4	210	19	151	90	20	90	10	218	80	19	8	14	7	50	80	100	34	5	2.3
	1/2, 3/4	225	19	166	106	20	106	10	241	90	25	10	14	9	55	88	110	50	9	3.2
AMG450	1	232	22	173	106	20	106	10	241	90	21	10	14	9	55	88	110	50	9	3.2
	3/4, 1	259	22	200	122	20	122	10	277	100	30	10	16	9	65	102	130	60	10	4.5
AMG650	1, 1 1/2	311	32	253	160	20	160	10	334	150	40	15	20	11	85	136	180	76	12	4.5



**AMG850 Dimensions**

**Accessory**  
**D: With auto-drain (N.O. type) for AMG850**

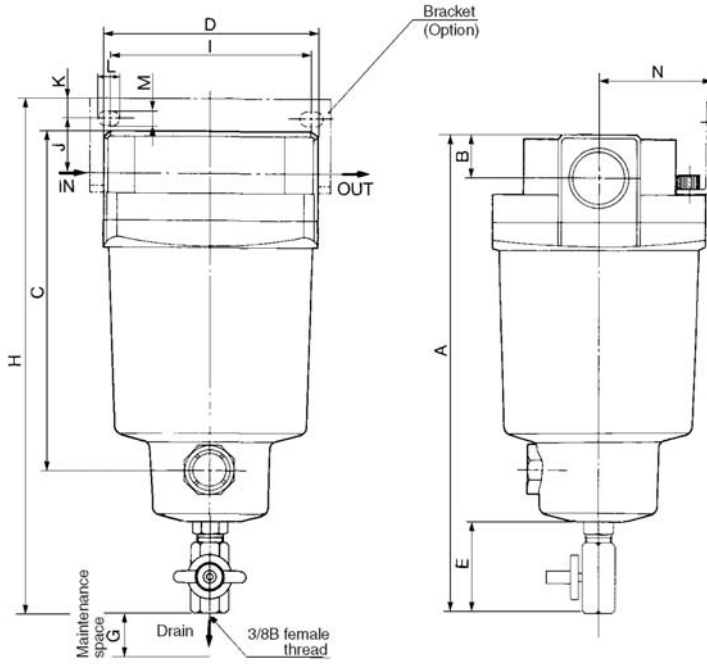
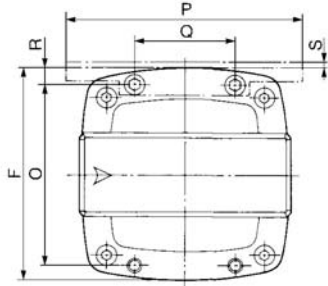

Model	Port size (Nominal size B)	A	B	C	D	E	F	G	Dimensions with mounting bracket											
									H	I	J	K	L	M	N	O	P	Q	R	S
<b>AMG850</b>	1/2, 2	460.5	42	348	220	57.5	220	10	463.5	180	30	15	24	13	120	184	220	110	18	6.0

## DEFENDER FEJLFINDINGS TIPS

KOMPONENT	PROBLEM	CORRECTION
<b>VACUUM TRANSFER MOTOR</b>	<p>1. Blæser ikke suge.</p> <p>2. Ingen vakuum ved vakuum slangen.</p> <p>3. Motoren tænder ikke.</p> <p>4. Afbryder CB1 slår fra når "Vakuüm Transfer kontakten" er tændt.</p>	<p>1. Åbn samleboks på motor og vend ledning nr. 5 &amp; 8. (Ametek Only)</p> <p>2a Bekræft at aftapningsventil og vakuum overførsels ventilen er lukket.</p> <p>2b Fjern pneumatiske aktuatorer fra ventiler for at bekræfte de er lukket.</p> <p>3a Bekræft at bump omskifter er i "Bump Set" position.</p> <p>3b Bekræft ledningsforbindelser.</p> <p>4a 220V strøm til RMF kabelforbundet forkert. Hot Leg skal være på L1.</p>
<b>RMF PROGRAMMER</b>	<p>1. Starter precoat mode, så stopper den og kun "system power" lyser.</p> <p>2. Begynder at precoat går derefter ind i filteret for tidligt.</p> <p>3. Pneumatikventiler virker ikke korrekt.</p> <p>4. RMF opererer ikke systemet. Power lys ikke tændt</p> <p>5. Programmering af precoat tid, har indflydelse på driftsprogrammet.</p> <p>6. Motor tænder ikke efter Bumpe eller cycle start.</p>	<p>1. Pumpen er ikke kablet til udgangene 4 &amp; 11. Sæt kabel i eller læg en lus for test.</p> <p>2. Precoat timeren er indstillet forkert. Bekræft mode "A" skala "0-30" range "min" indstillet til 10 minutter.</p> <p>3. Bekræft at rør forbindelser fra magnetventiler er ført korrekt ventil aktuator nederst på hver magnetventil. Der er en label som viser hvilken ventil der hører til de forskellige funktioner. Hit cycle stop på RMF. Hver magnetventil på bunden har en manuel knap (blå) for at aktivere. Brug en blyant eller lign. for at trykke på knappen. Hold i stilling og bekræft at den afmærkede ventil åbnes. Hvis dette ikke er tilfældet ændres rørføringen til det korrekte</p> <p>4a Bekræft afbrydere i RMF er på (up position) 4b Check indgående 220V power</p> <p>5. Precoat timer i mode "C", skifte til mode "A".</p> <p>6a. Check interface ledningerne RMF terminaler 4, 11 &amp; 39, 40.</p> <p>6b Check programmering af motor-starteren. Omprogrammere hvis det er nødvendigt.</p>
	<p>7. "Cycle Start" knappen fungerer ikke.</p>	<p>7a Tryk på "Cycle Stop"-knapen for at nulstille. Tryk så på "Cycle Start".</p> <p>7b Bekræft "Bump Set"-knapen er i manuel eller auto stilling.</p>



<p><b>PNEUMATIC ACTUATORS</b></p>	<p>1. Ventilaktuatorer cykler ikke korrekt</p> <p>2 ventilaktuatorer opererer ikke</p> <p>3. Ventilaktuatorer bevæger sig for hurtigt</p> <p>4. Ventil skive sidder i øjeblikket fast i lukket position.</p>	<p>1. Se RMF programmør punkt nr. 3</p> <p>2a Check lufttryk. Bekræft filter / regulator er sat til 90 PSI.</p> <p>2b Kontroller luftlinje slangen er fastgjort korrekt. Kontroller for utætheder i luftlinjer.</p> <p>2c Hvis luftlinjen har utætheder ved tilslutninger, fjern slanger og re-cut firkantet og indsæt.</p> <p>2d Bekræft flow reguleringsventiler på aktuatorer er åbne mindst 1,5 sving . Åbn mere, hvis ventilen ikke bevæger sig.</p> <p>3. Sluk luften. Afbryd luftlinjen fra aktuatoren, og tilslut linjen fra højre side af porten ind i den enkelte port på luften kontakten (inkluderet med værktøjskasse). Tilslut ¼ "O.D. slange i den dobbelte port i luft kontakten og oprette forbindelse til aktuator portene. Flytning af kontakten frem og tilbage vil operere aktuatoren. Juster strømmen reguleringsventilerne hvis nødvendigt, for at regulere ventilens hastighed for at lettere åbne / lukke.</p> <p>4a Prøv at justere strømmen i reguleringsventilerne som beskrevet i punkt 3 ovenfor .</p> <p>4b Juster ende stop for at lukke til vinkelret position. Vinkelret position er defineret som den lukkede position, hvor disken ikke lækker, men er mindre end 100% lukket. Se brugsvejledningen for ende stop justering ved hjælp af tool kit.</p>
<p><b>FILTER TANK</b></p>	<p>1. Tank drænes langsomt</p>	<p>1a Imens systemet filtrerer, åbn aftapningsventil for at sende lede vandtryk igennem røret.</p> <p>1b Åbn vakuum aftapningsventil</p>
<p><b>BUMP MECHANISM</b></p>	<p>1. Støder ikke. Sidder fast i opstående position</p>	<p>1a Bekræft at automat udlufter er installeret korrekt.</p> <p>1b Åbn tank aftapningsventilen for at lindre pres. Flyt bump omskifter/kontakt til "bump sæt". Tryk bump knap 5-10 gange. Systemet bør bump korrekt ved den næste cycle.</p> <p>1c Bekræft VFD / Soft Starter rampe tid er indstillet til "0" sekunder.,</p>

## **INSTRUKTIONER FOR ENHVER BEGIVENHED, der forårsager at DEFENDER FILTRET lukker ned (andet end at trykke på CYKLUS STOP-knappen)**

- 1.)** Kontroller, at der er strøm til kompressoren, og at den er funktionel.
- 2.)** Kontroller, at trykregulator på Defender-filter aflæses til omtrent 90 PSI (60 PSI minimum).
- 3.)** Kontroller, at der er strøm til RMF panel (den hvide indikator for SYSTEM power Er tændt). Hvis ikke, kan du kontrollere, at de (2) afbrydere (CB1 & CB2) inde i panelet er tændt.
- 4.)** Kontroller at alle kontakter på RMF panelet er i den korrekte position (i tilfælde af at nogen kom ind og flyttede ting, under strømafbrydelsen). Bump Selector skal være Tændt for enten manuelt eller AUTO (ikke BUMP SET), Vacuum Transfer kontakten er OFF, "indtastet" Maintenance Mode-kontakten er i positionen OFF, og PRECOAT timer (indeni RMF panel) er indstillet til 10 minutter.
- 5.)** Kontrollér, at alle (3) pneumatiske aktiverede ventiler (INFFLUENT, EFFLUENT & PRECOAT) er i lukket stilling (systemt er designet til at lukke alle (3) ventiler, når pumpen lukkes, som ville opstå, når du mister power). Der er en gul indikator, på den sorte skive placeret øverst på aktuatorer, der simulerer / repræsenterer placeringen af disken i ventilen. Hvis nogen af ventilerne IKKE er i lukket stilling, skal du tjekke hvorfor de er ikke er det (sidder ventil fysisk fast i åben stilling, er der trykket luft på vej ud til ventilen for at lukke den, er der nogen løse ledninger på undersiden af klemmestik til magnetventiler.)
- 6.)** Når alle (3) ventiler er fast besluttet på at være i lukket stilling, så trykker du på cycle STOP-knappen, og derefter tryk på CYCLE START-knappen. BEMÆRK: Hvis du ønsker at dobbelt-tjekke, at alt er i orden, før du starter filter systemet, så slukke for strømmen til pumpen og sætte en jumper ledning mellem terminal # 4 - og 11 på klemmerækken inde i RMF panelet. Det vil "simulere" at pumpen kører (dette er drift kredsløbet), så programmet kommer til at fungere og gå gennem sin cyklus. Nu når du trykker på CYCLE START-knappen vil aktuatorer åbne og lukke som de bør, men der vil ikke gå vand igennem filteret, fordi pumpen ikke kører.  
Husk at fjerne jumper ledningen og sæt strøm til pumpen efter dette er gjort.

Filteret Systemet skal nu starte i regenerations tilstand og derefter gå til FILTER mode.